

AIRTECH

Condensation, Mould & Radon Specialists

Air+ Wall Positive Input Ventilation Unit

Product Datasheet



- 7 year product guarantee
- Energy efficient – consumes as little as 4 Watts
- Extremely compact - able to be fully hidden behind 200x200mm decorative boxing
- DC motor and anti-vibration EPP body for ultra quiet operation
- Removable cartridge for easy repair and replacement
- Pre-heater facility as standard
- Fully adjustable airflow up to 30l/s or 4 pre-set speeds for ease of installation
- Air temperature cut out when incoming air temperature is high and is fully adjustable

Order Code

PIV/W Air+ Wall PIV Unit

Benefits

- Very quiet
- Lower energy costs for tenant in keeping with Government Directive regarding energy efficient appliances in Social Housing
- Helps to alleviate condensation
- Reduces radon
- Low maintenance

General

- Robust, anti-vibration and condensation resistant construction
- Extremely compact to ensure the most discreet installation every time
- Preheat and airflow rates can be fully adjusted to ensure resident comfort
- Electronic controller automatically monitors temperature of introduced air and activates pre-heat to maintain comfort levels. If the heater switch is enabled by the tenant the heater will switch on when the air temperature falls below the predefined threshold
- Extra large filter area to maximise filter life

Installation

The Air+ Wall unit is generally fitted on a convenient wall as close to the air intake point as possible. Ideally this should be within a hall cupboard where access to an external wall and ambient air is possible. Supply ducting is run to an outlet air grille normally located in the hallway so that air is delivered to a central point within the dwelling.

Fan Dimensions (mm)

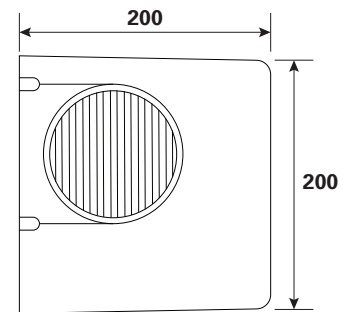
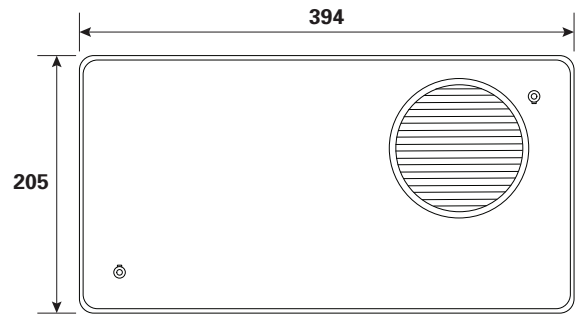

Product Performance

Supply Volume:

Setting	Air flow (l/s)	Power (W)	Sound (dB)
1	13	6	11.6
2	17	8	18.9
3	21	9	25.4
4	25	11	29.7

Fan Technical Data

Voltage (V)	220/240
Intake & Outlet (mm)	100
Supply Ducting (mm)	100
Heater (W)	300