

# DEXA HR Plus+

## Single Room Heat Recovery Unit with Advanced User Control

---

### **INSTALLATION, MAINTENANCE & USER GUIDE**

Read this manual carefully before using the product and keep it in a safe place for reference. This product was constructed up to standard and in compliance with regulations relating to electrical equipment and must be installed by technically qualified personnel. The manufacturer assumes no responsibility for damage to persons or property resulting from failure to observe the regulations contained in this booklet.

# PRECAUTIONS FOR INSTALLATION, USE & MAINTENANCE

01. The device should not be used for applications other than those specified in this manual.
02. After removing the product from its packaging, verify its condition. In case of doubt, contact a qualified technician. Do not leave packaging within the reach of small children or people with disabilities.
03. Do not touch the appliance with wet or damp hands/feet.
04. This appliance can be used by children aged from 8 years and above and persons with reduced physical, sensory or mental capabilities or lack of experience and knowledge if they have been given supervision or instruction concerning use of the appliance in a safe way and understand the hazards involved. Children shall not play with the appliance. Cleaning and user maintenance shall not be made by children without supervision.
05. Do not use the product in the presence of flammable vapours, such as alcohol, insecticides, gasoline, etc.
06. If any abnormalities in operation are detected, disconnect the device from the mains supply and contact a qualified technician immediately. Use original spare parts only for repairs.
07. The electrical system to which the device is connected must comply with regulations.
08. Before connecting the product to the power supply or the power outlet, ensure that:
  - the data plate (voltage and frequency) correspond to those of the electrical mains
  - the electrical power supply/socket is adequate for maximum device power. If not, contact a qualified technician.
09. The device should not be used as an activator for water heaters, stoves, etc., nor should it discharge into hot air/fume vent ducts deriving from any type of combustion unit. It must expel air outside via its own duct.
10. Operating temperature: -20°C up to +50°C.
11. The device is designed to extract clean air only, i.e. without grease, soot, chemical or corrosive agents, or flammable or explosive mixtures.
12. Do not leave the device exposed to atmospheric agents (rain, sun, snow, etc.).
13. Do not immerse the device or its parts in water or other liquids.
14. Turn off the main switch whenever a malfunction is detected or when cleaning.
15. For installation an omnipolar switch should be incorporated in the fixed wiring, in accordance with the wiring regulations, to provide a full disconnection under overvoltage category III conditions (contact opening distance equal to or greater than 3mm).
16. If the supply cord is damaged, it must be replaced by the manufacturer, its service agent or similarly qualified persons in order to avoid a hazard.
17. Do not obstruct the fan or exhaust grille to ensure optimum air passage.
18. Ensure adequate air return/discharge into/ from the room in compliance with existing regulations in order to ensure proper device operation.
19. If the environment in which the product is installed also houses a fuel-operating device (water heater, methane stove etc., that is not a "sealed chamber" type), it is essential to ensure adequate air intake, to ensure good combustion and proper equipment operation.
20. Install the product so that the impeller is not accessible from the air outlet side as verified by contact with the Test Finger (test probe "B" of the norm EN61032) in compliance with the current safety regulations.

01384 275771

info@eltatrade.co.uk

**www.eltatrade.co.uk**

# INTRODUCTION

DEXA HR Plus+ is a single alternate flow decentralized (single point) residential heat recovery unit, also called a push & pull unit, designed to ensure adequate ventilation in enclosed environments without energy losses.

It is recommended that two units are installed in a pair: when one unit is pulling, the other is pushing.

The pair of units can be installed in the same room or in different rooms (i.e. living-room and bedroom). The unit is suitable for installation on an outside wall.

**IMPORTANT:** The unit should operate continuously, and only stopped for maintenance or service. When heat exchange is not useful (for example in mid-seasons when indoor and outdoor temperatures are similar), or when heat exchange is not recommended (for example with the option “summer free cooling”), it is recommended to set the unit in “extract-only” or “intake-only” mode and **NOT** to switch it off.

## TECHNICAL SPECIFICATION

- Modern design front cover (A) removable for cleaning without the use of tools.
- Inner ventilation unit (B) and wall support base (D) made of high quality, impact and UV-resistant ABS, colour RAL 9010.
- Integrated multi-colour led (C) to obtain a visual feedback of the unit status.
- Smart humidity control.
- Integral temperature sensor for the automatic management of the inversion time (comfort mode).
- Automatic anti-frost protection to prevent frost building up on the heat exchanger.
- Wall support base (D) provided with a magnet “coupling/uncoupling” system which allows the ventilation unit to be removed from its base during maintenance.
- Back-up touch button (J) at the side of the ventilation unit.
- Unique design winglet-type impeller, providing enhanced aerodynamic properties, low noise and increased efficiency.
- High efficient reversible EC motor with integral thermal protection, mounted on sealed for life high quality ball bearings. Designed for continuous reversible running.
- Telescopic pipe (F) adaptable to the wall thickness.
- Antimortar cap designed to be used also as template during the installation of the wall support base.
- Regenerative heat exchanger with ceramic core (G) with high thermal efficiency, equipped with washable anti-dust filters (H).
- External grille (I) made of high quality, impact and UV-resistant ABS, colour RAL 9010, with anti-insect net and water drip guard.
- Infra-red remote controller with touch technology, LCD display and wall base supplied as standard. Made from ABS, RAL 9010.
- No need of condensation drainage system.
- IPX4 degree of protection.
- Power supply 220-240V~ 50Hz.

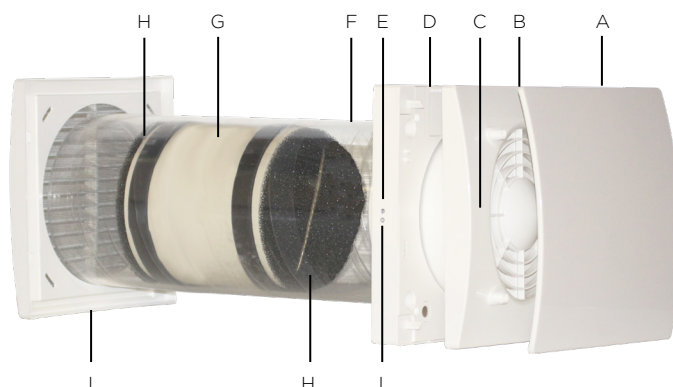

01384 275771

info@eltatrade.co.uk

[www.eltatrade.co.uk](http://www.eltatrade.co.uk)

# OPERATION

## REMOTE CONTROL

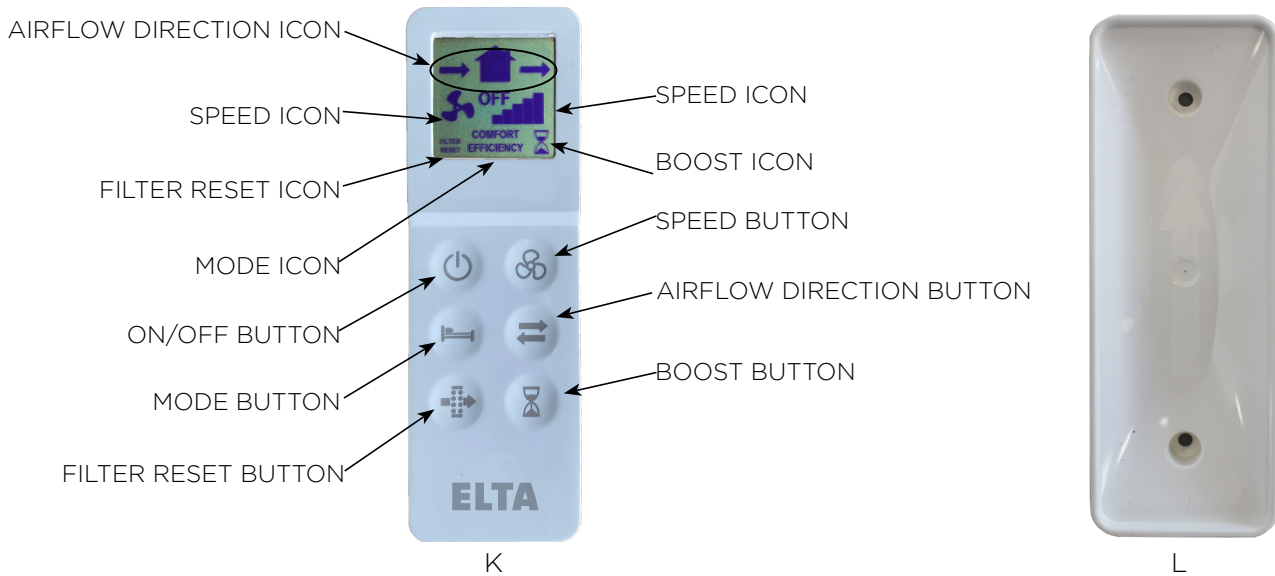

The unit is supplied with an infra-red remote controller (K) as standard, as well as its support base (L) which can be wall mounted. A magnet keeps the controller attached to the base.

The controller is equipped with an LCD display to visualise the setting to be transferred to the unit; anytime a touch button is pressed, the setting shown on the LCD display is transferred to the unit. The IR receiver is placed on the left side of the ventilation unit (E): it is recommended to point the controller towards the receiver when any setting needs to be transferred.

One remote controller can control multiple units.

To activate the remote controller, it is necessary to insert two AAA type batteries (not supplied).

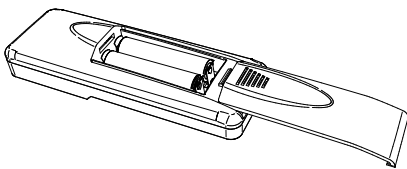





























When the unit is switched on, it emits a long acoustic signal.

Through the IR controller, the functionalities shown in the table on the following page can be activated/deactivated. When one setting is transferred to the unit, a short acoustic signal is emitted and a green LED flashes.

01384 275771

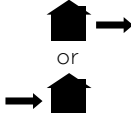
info@eltatrade.co.uk

**www.eltatrade.co.uk**

FUNCTIONALITY & DESCRIPTION		CONTROLLER BUTTON	ICON	LED	ACOUSTIC SIGNAL
<b>AIRFLOW DIRECTION</b>					
Alternate	The unit runs in extract/intake at the selected speed: the inversion time is automatically defined thanks to the integral temperature sensor (comfort mode).			Green	Short
Extract	The unit runs in extract only at the selected speed.			Green	Short
Intake	The unit runs in intake only at the selected speed.			Green	Short
<b>MODE</b> (active only if the airflow direction is set on alternate)					
Comfort	Optimisation of the acoustic and thermal comfort. The inversion time varies automatically from 40-120 seconds, thanks to the integral temperature sensor. The first time cycle is of 70 seconds, then it varies automatically according to the detected temperature conditions.			Green	Short
Efficiency	Optimisation of the thermal efficiency. The inversion time is fixed at approx. 70 seconds.			Green	Short
<b>CONTINUOUS RUNNING SPEED</b>					
Speed 1: 20m <sup>3</sup> /h				Green	Short
Speed 2: 30m <sup>3</sup> /h				Green	Short
Speed 3: 40m <sup>3</sup> /h				Green	Short
Speed 4: 50m <sup>3</sup> /h				Green	Short
Speed 5: 60m <sup>3</sup> /h				Green	Short
<b>ON/OFF</b>					
Unit can be switched on or off.			Off LCD ON	Red Green	Long Short
<b>BOOST SPEED</b>					
The unit runs at speed 5 (maximum) for 15 minutes, in extract only; then it returns to the previously selected mode/speed. The BOOST speed cannot be activated if the controller is OFF.				Fixed Blue	Short
<b>FREE COOLING</b>					
The unit runs in "extract only" or "intake only" to avoid heat recovery when not needed.				Green	Short
<b>FILTER RESET</b>					
Every 3 months, a yellow warning LED switches on (fixed light) to indicate that the filters have to be maintained. Press the dedicated button for 5 seconds to reset the timing.			FILTER RESET	Yellow	Short
<b>SMART HUMIDITY CONTROL</b>					
When the humidity sensor detects a quick variation of the Relative Humidity level, the running speed automatically increases to the next higher speed. After 10 minutes from the last quick RH variation, the unit returns to running at the selected speed. The smart humidity control is active if the airflow direction is set on alternate or extract only: if speed 5 has been selected, no speed increase happens. To disable this functionality, press the  button for 5 seconds: on the top side of the LCD display the ● symbol is shown.				Flashing Blue	
<b>ANTIFROST</b>					
This functionality prevents frost building up on the heat exchanger due to extremely cold air. When it is activated, the unit runs in extract only, at speed 1, for 30 minutes.				Fixed Red	
<b>ACOUSTIC SIGNAL</b>					
Any time a setting is transferred from the controller to the unit, a short acoustic signal is emitted. This can be deactivated by pressing the  button for 7 seconds, a green LED flashes to indicate that the acoustic signal is off. To reactivate the acoustic signal repeat the same operation for 7 seconds until the LED becomes green and an acoustic signal is emitted.				Green	Short

## BACK UP BUTTON

In case the remote controller gets lost or the batteries are dead, ON and OFF position can be selected from the on board touch button (J), pressing the button for at least 3 seconds.

	LED COLOUR	ACOUSTIC SIGNAL
ON	Green	Short
OFF	Red	Long

## SYNCHRONISATION OF A NUMBER OF UNITS

It is possible to synchronise up to 10 units contemporaneously, through wire (2 pole twisted pair type, max 30m length) so to have mode and inversion time synchronised. When the unit is switched on for the first time, the rotation direction of each unit (clockwise or anti-clockwise) is automatically established. Other functionalities like speed, smart humidity control and boost, continue to be controlled independently on each single unit. Wiring diagram as per fig. 15B.

## TROUBLE SHOOTING

ANOMALY	POSSIBLE CAUSE	SOLUTION
No icon shown on the controller LCD display	Batteries are dead	Change the batteries
	Batteries are not present	Check that batteries are present
	Batteries are wrongly positioned	Position the batteries correctly
The icon ▲ flashes on the LCD display	Low batteries	Change the batteries
The unit does not execute the command sent from the remote control	Lack of communication between the unit and the remote controller	Go closer to the unit, pointing the controller to the receiver on the left side of the unit
The unit does not operate	There is no voltage	Check that the unit is correctly wired to the main supply
	Ventilation unit does not couple correctly with the support base	Check that the coupling is correct
The unit operates at the maximum speed	The boost functionality is activated, on the display the icon ⏸ is shown	Wait until the boost timing ends (15 minutes) or deactivate the boost function pressing the ⏸ button.
Unit speed suddenly increases	The smart humidity control is activated	Wait until the smart humidity control phase ends (10 minutes) or deactivate the humidity control function pressing the ⏸ button for 5 seconds.
Fixed yellow led	Dirty filters	Filters maintenance/replacement is needed: reset filter operation has to be done
Fixed red led	Antifrost protection is activated	Wait until the antifrost phase ends (30 minutes)
Fixed blue led	Boost is activated	Wait until the boost timing ends (15 minutes) or deactivate the boost function pressing the ⏸ button.
Flashing blue led	Smart humidity control is activated	Wait until the humidity control phase ends (10 minutes)
Fixed purple led	Ventilation unit does not couple correctly with the support base	Check that the coupling is properly done
Acoustic signal to disable -	-	Press the ⏸ button for 7 seconds: a green led flashes

01384 275771

info@eltatrade.co.uk

**www.eltatrade.co.uk**

# DIMENSIONS

Model	A	B	C	ØD	E	F	G	H	I	L	M
DEXA HR 100 Plus+	218	77.5	270-510	108	164	117.5	39	23	124	44	26.5
DEXA HR 150 Plus+	218	77.5	300-560	158	218	117.5	39	23	124	44	26.5

Dimensions in mm.

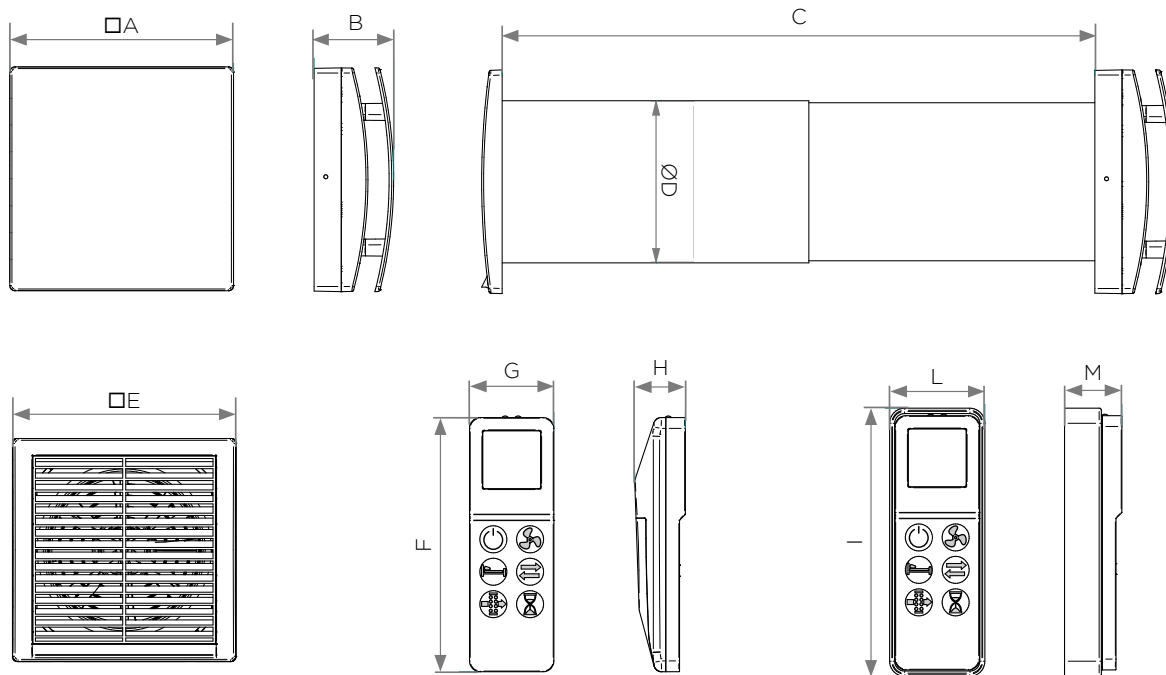

# INSTALLATION

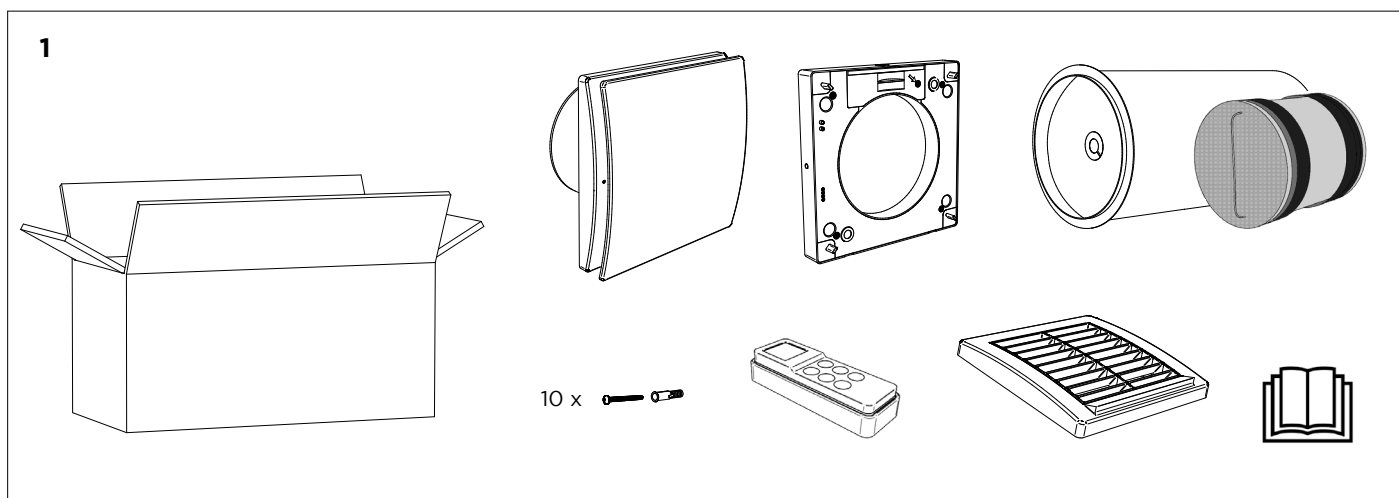

Check the contents of the box to make sure all items are present.

**IMPORTANT:** When installing the fan, it is essential that the centre of the unit is located **300mm** from all obstacles, walls and ceilings to ensure correct airflow around the unit.

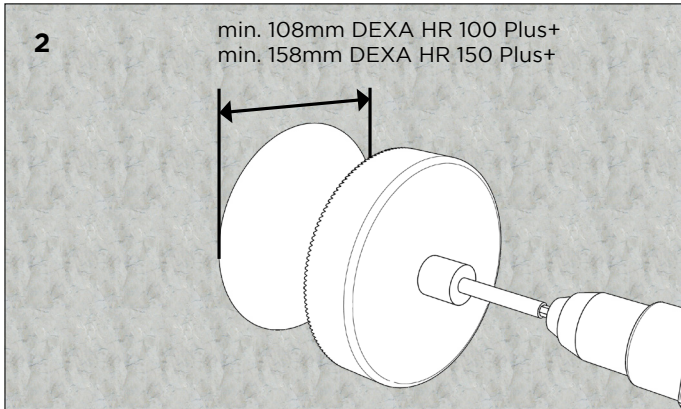

The hole in the wall should be the size noted above depending on the unit.

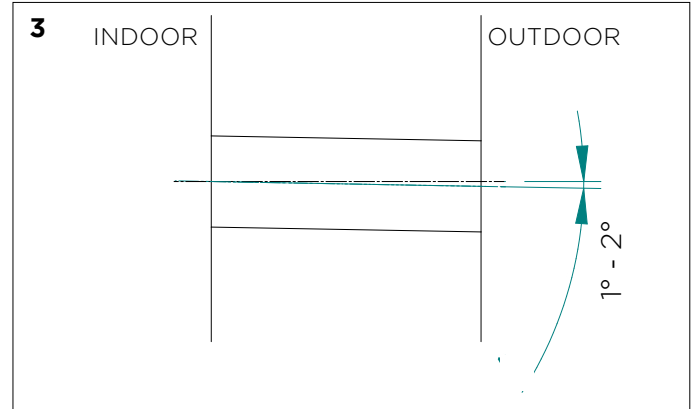

When drilling the hole for the ducting, ensure there is a slight fall of 1 - 2 degrees from the inside to outside.

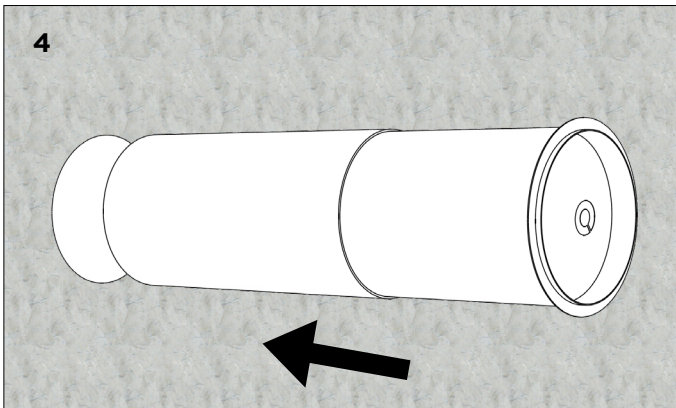

Put the telescopic duct into the wall and adjust the length to suit. The duct should extend 3-5mm from the surface of the outside wall to ensure correct sealing with the grille when installed.

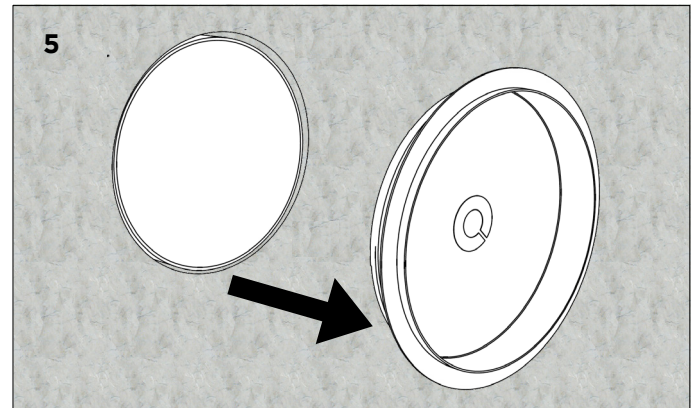

Remove the anti-mortar cap.

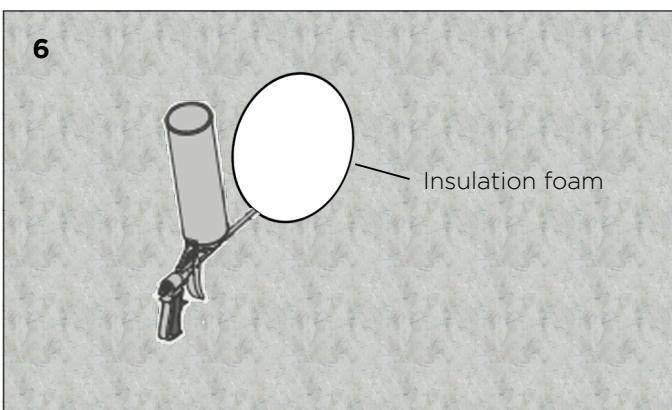

Using expanding insulation foam, seal around the tube.

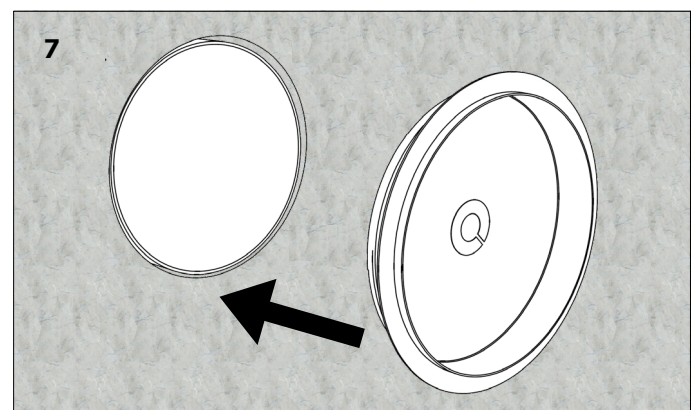

Once the insulation foam has dried and been trimmed, replace the anti-mortar cap.



## RECESSED CABLE ENTRY

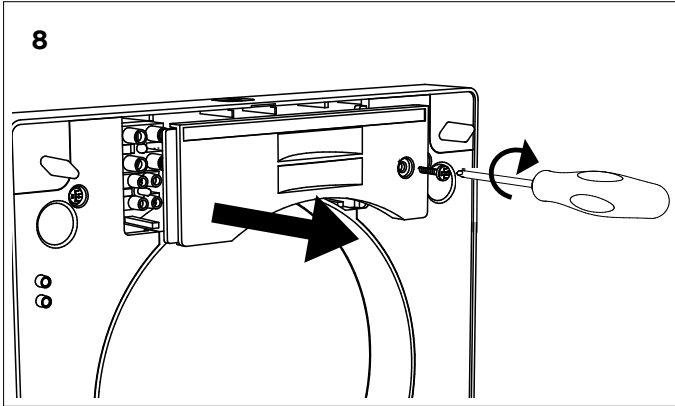

Pull the magnetic face plate from the unit back plate. Remove the cover screw and then the electrical cover.

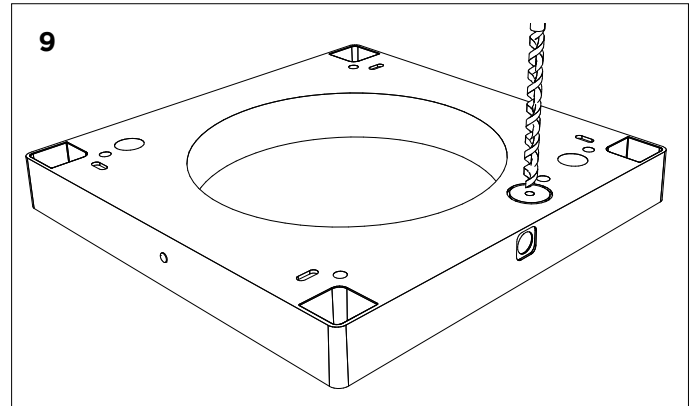

Drill out and remove the rear cable entry knockout.

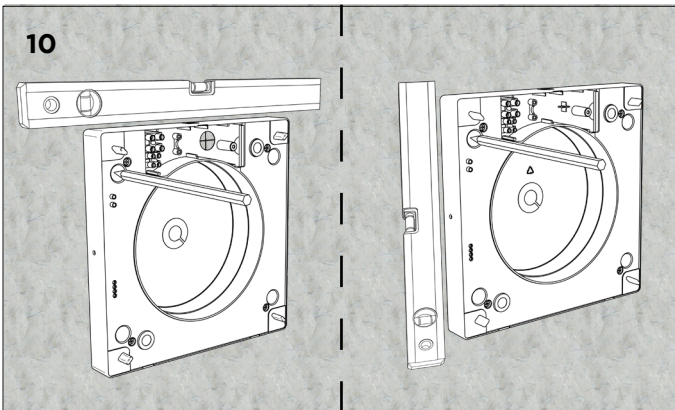

Locate the unit backplate over the hole, the anti-mortar cap is designed to accurately locate the mounting position. Level the unit and mark the mounting holes.

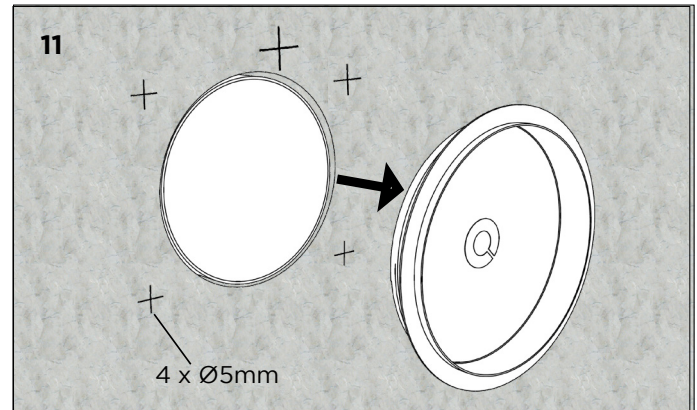

Drill the mounting holes as per the image above then remove the anti-mortar cap.

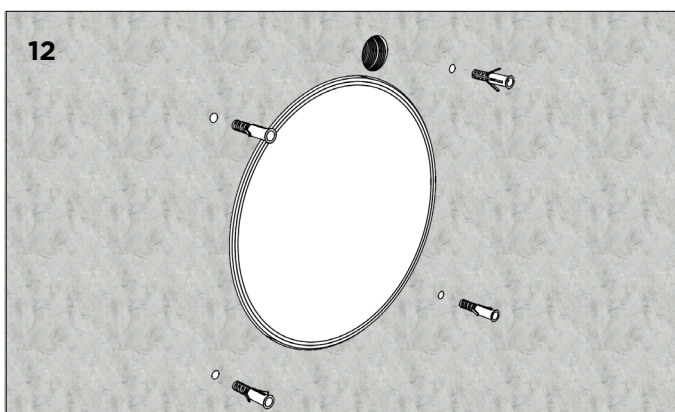

Insert the 4 supplied wall plugs. If you are mounting to other surfaces, other fixings (not supplied) may be required.

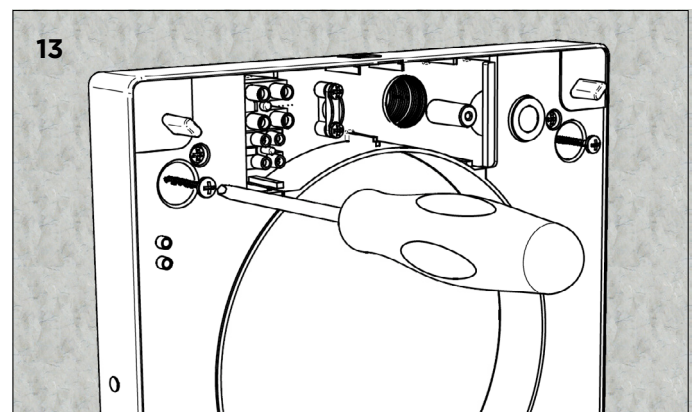

Affix the back plate to the wall with the 4 screws supplied. If you are mounting to other surfaces, other fixings (not supplied) may be required.

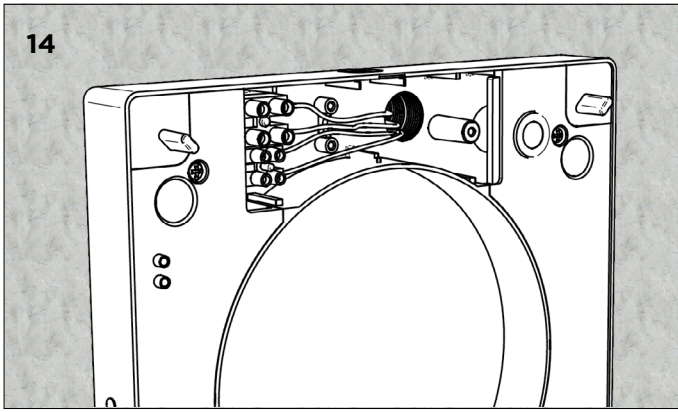

14  
Terminate the wiring as per the wiring diagrams.

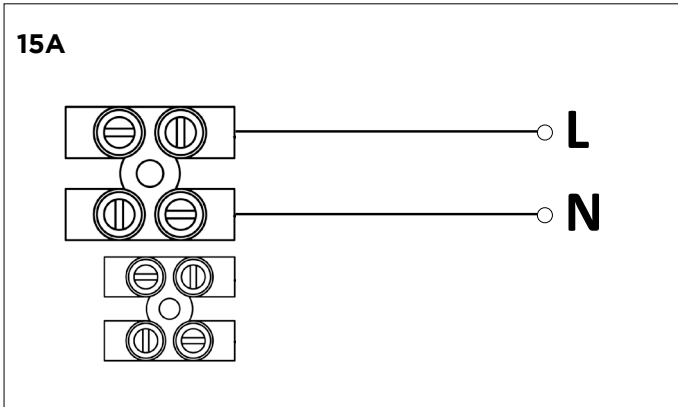

15A  
Wiring diagram for a single unit.

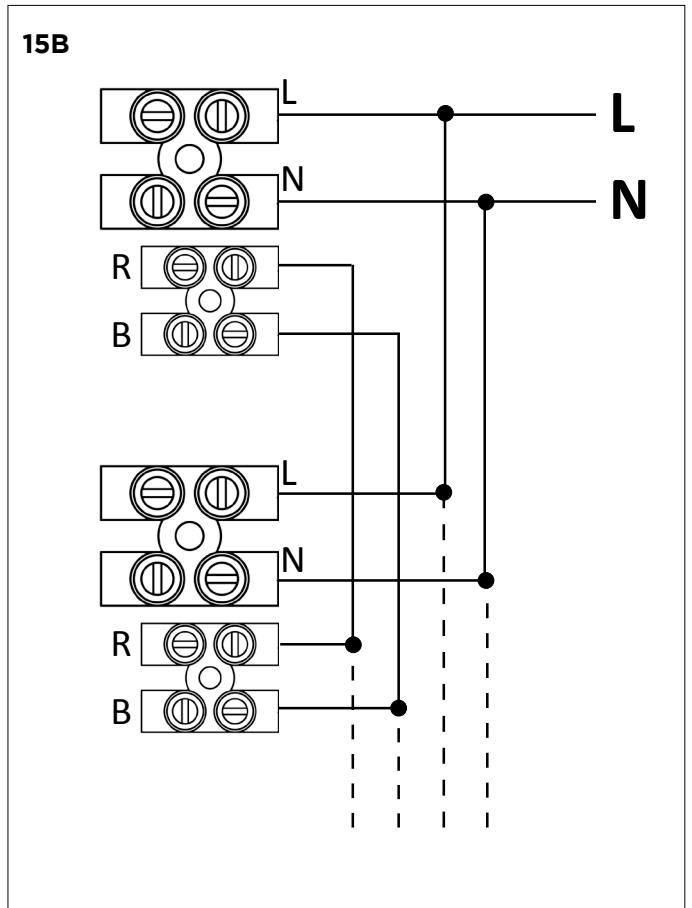

15B  
Wiring diagram for multiple units with a twisted pair connection.

**WARNING:** Care should be taken when handling the ceramic heat exchanger to avoid damage.

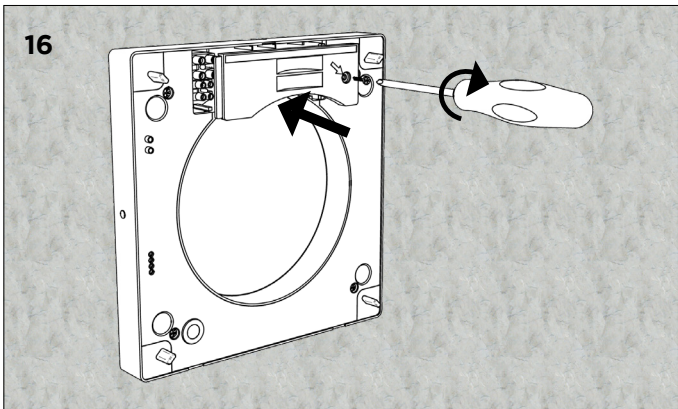

16  
Reinstall the connections cover.

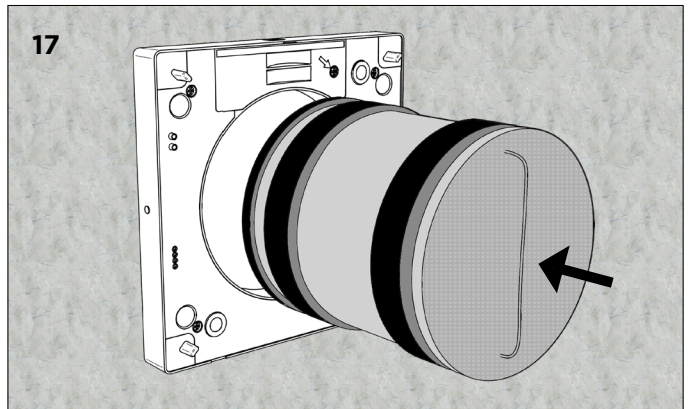

17  
Insert the filter and heater core assembly into the ducting.

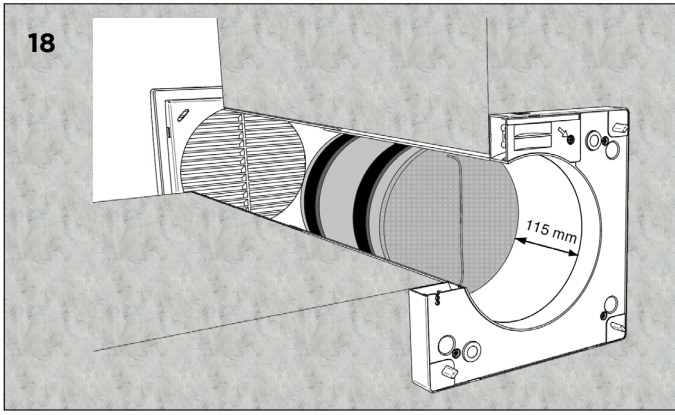

The exchanger should be seated in the ducting at the depth shown.

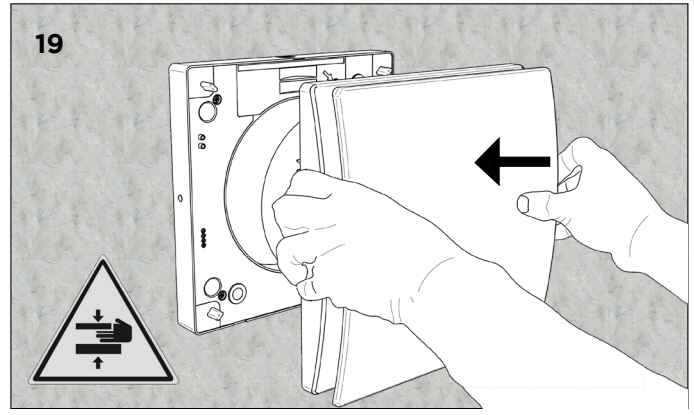

Re-attach the magnetic front cover. Be careful to ensure nothing is between the 2 parts.

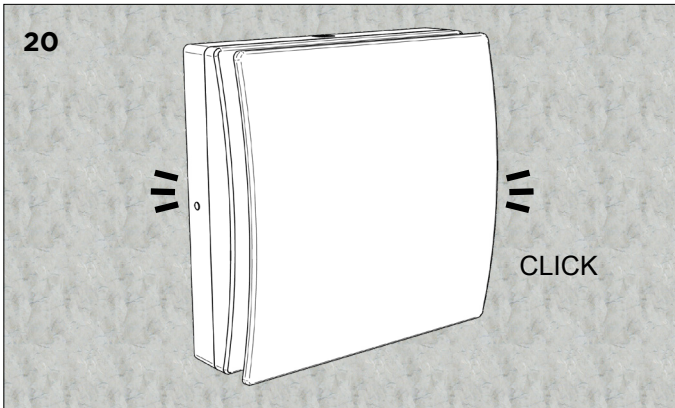

The unit will click together when seated correctly.

**SURFACE CABLE (for one unit wiring)**

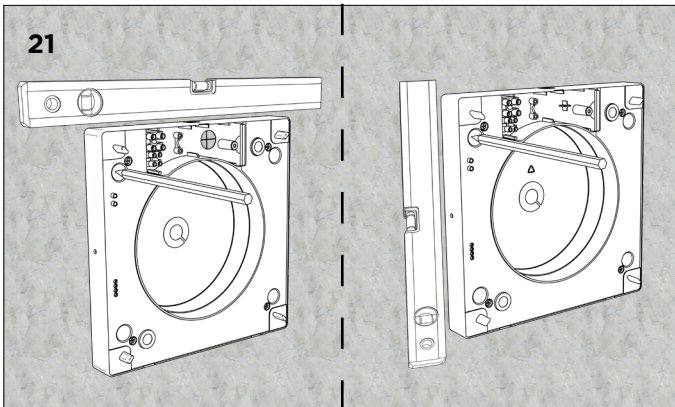

Locate the unit backplate over the hole, the anti-mortar cap is designed to accurately locate the mounting position. Level the unit and mark the mounting holes.

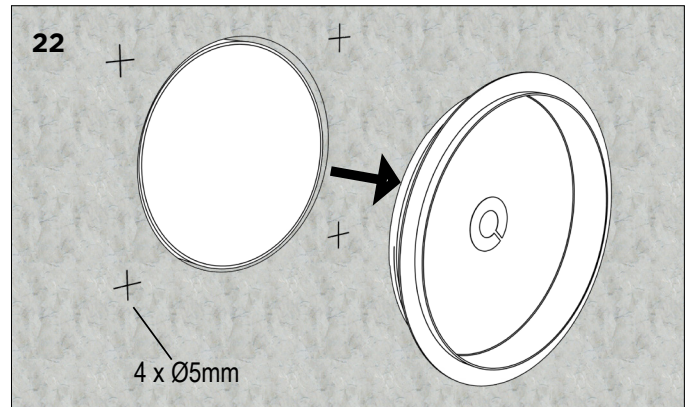

Drill the mounting holes as per the image above then remove the anti-mortar cap.

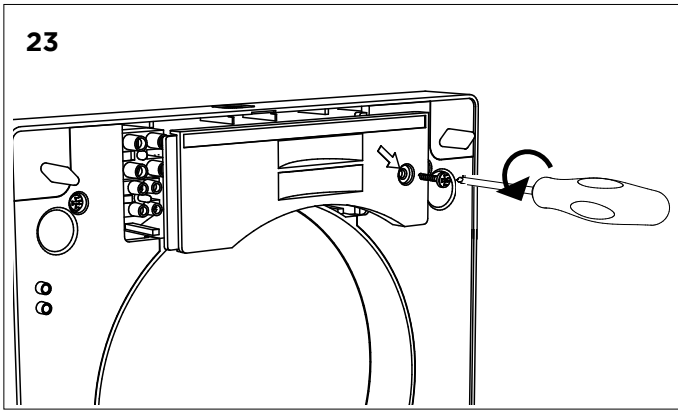

23 Pull the magnetic face plate from the unit back plate. Remove the cover screw and then the electrical cover.

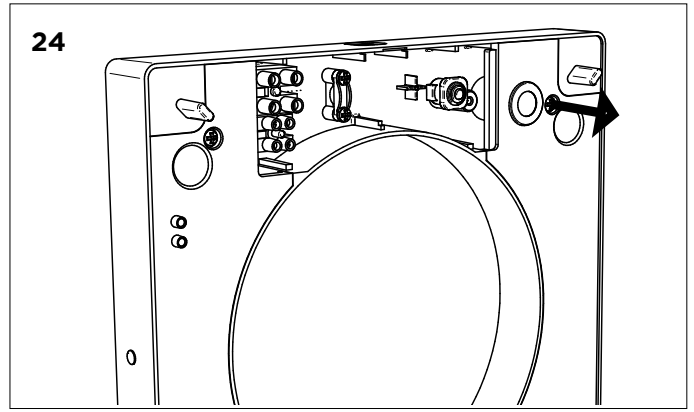

24 Remove the rubber cable grommet located on the back plate and remove.

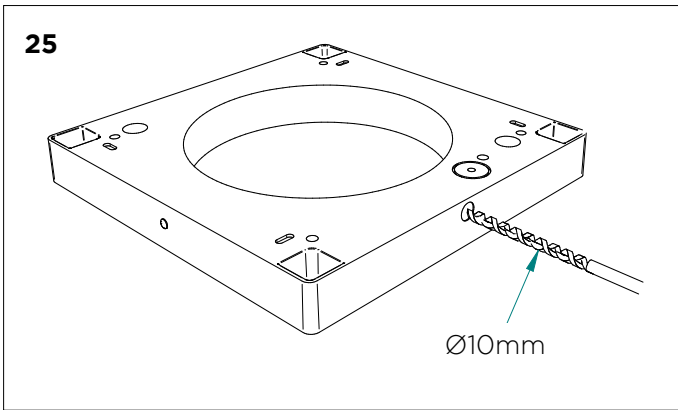

25 Drill the cable entry of the back plate out.

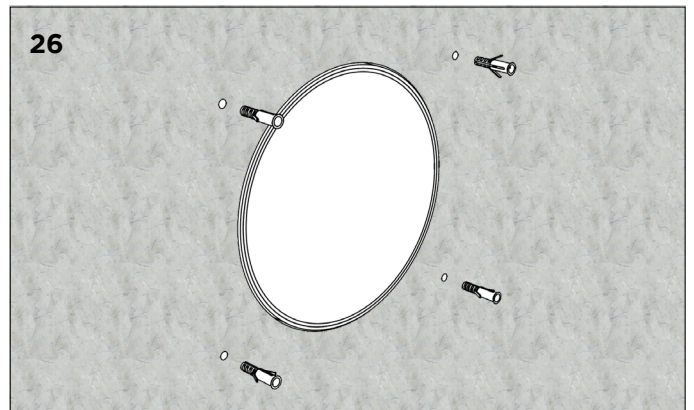

26 Insert the 4 supplied wall plugs. If you are mounting to other surfaces, other fixings (not supplied) may be required.

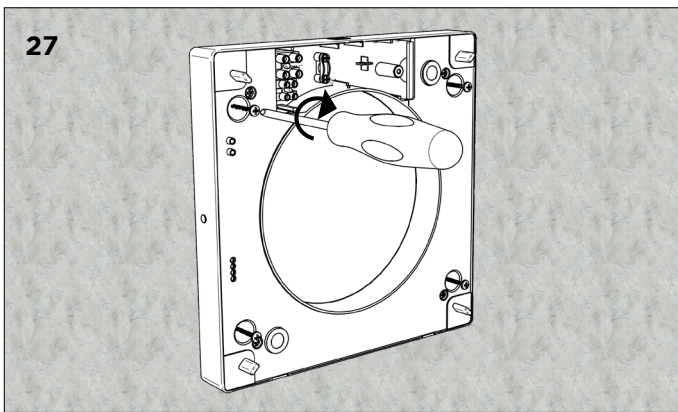

27 Drill the cable entry of the back plate out.

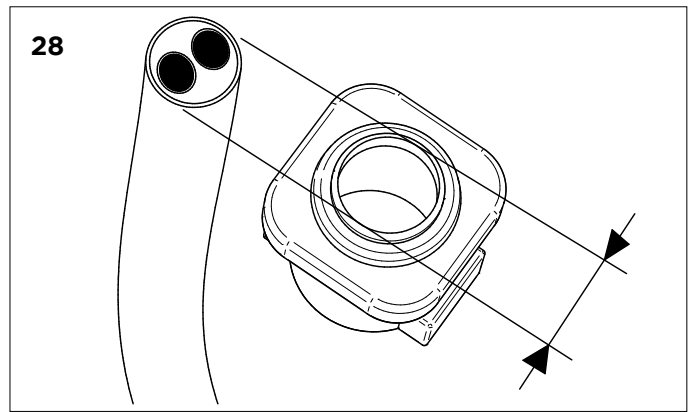

28 Open the cable grommet to the same size as the supply cable diameter.

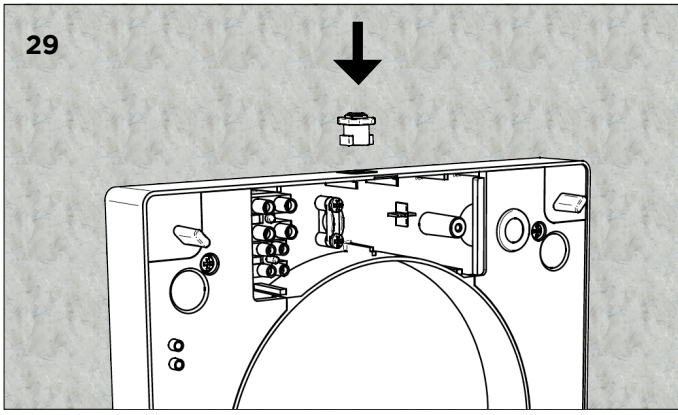

Insert the cable grommet into the hole drilled earlier.

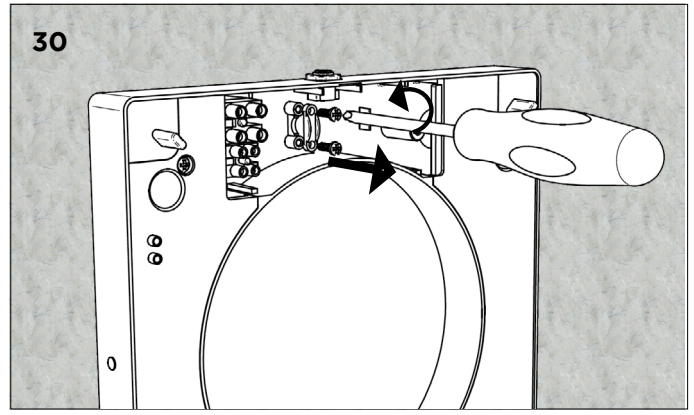

Loosen the two screws on the cable grip.

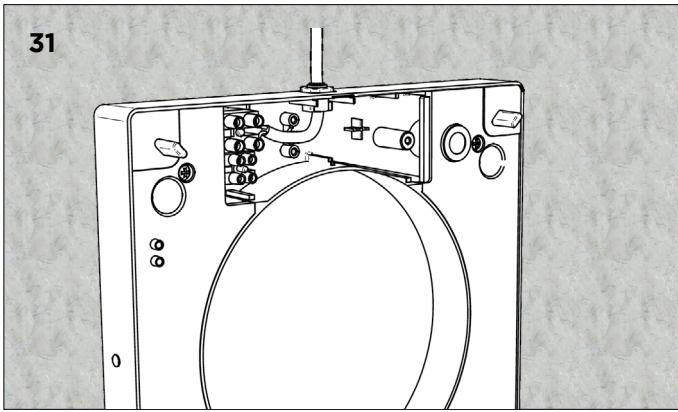

Insert the supply cable into the grommet and measure to the correct length.

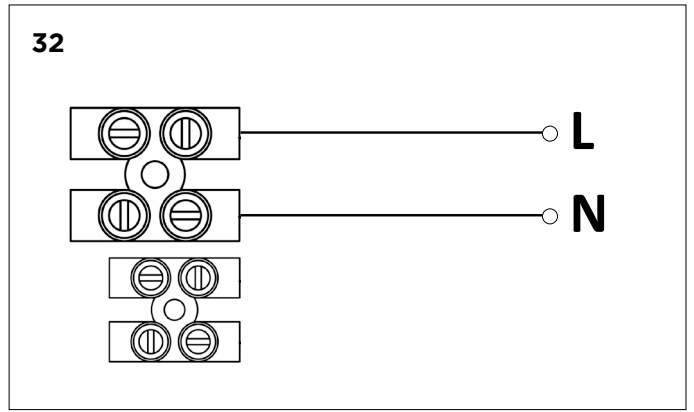

Wiring diagram.

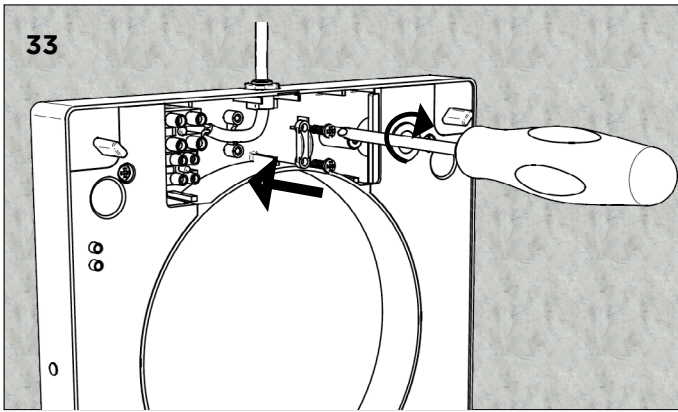

Once terminated, re-tighten the cable grip.

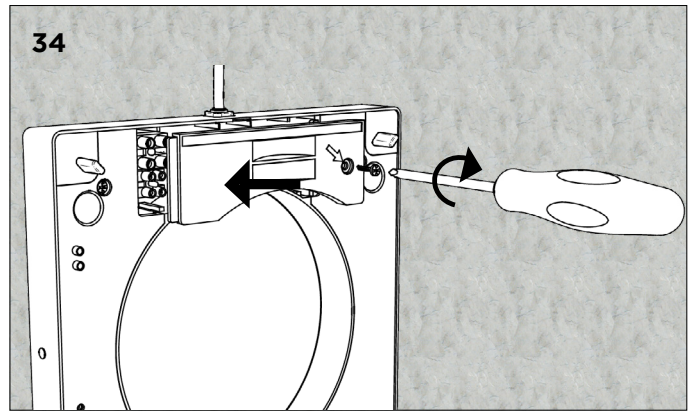

Reinstall the connections cover.

**WARNING:** Care should be taken when handling the ceramic heat exchanger to avoid damage.

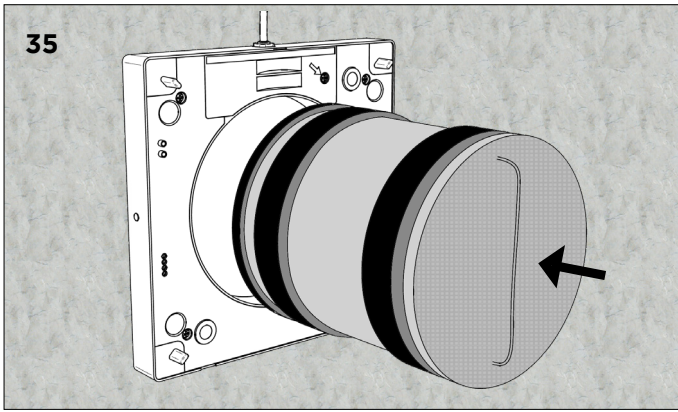

Insert the filter and heater core assembly into the ducting.

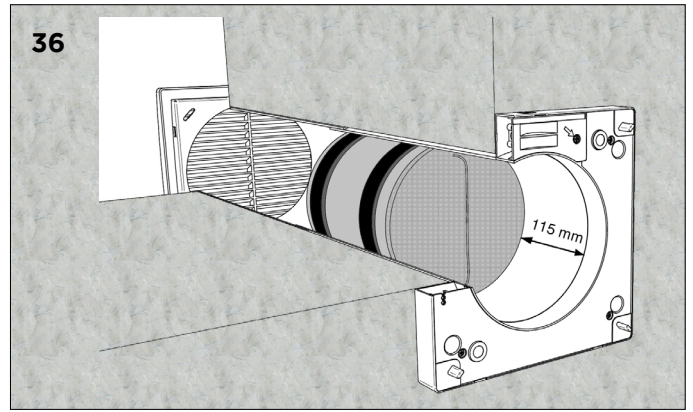

The exchanger should be seated in the ducting at the depth shown.

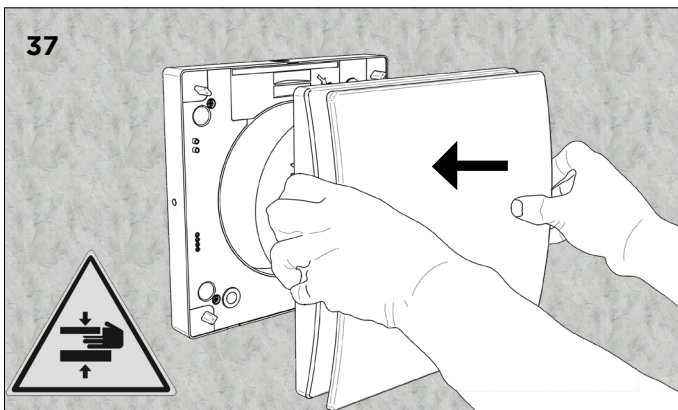

Re-attach the magnetic front cover. Be careful to ensure no body parts are between the 2 parts.

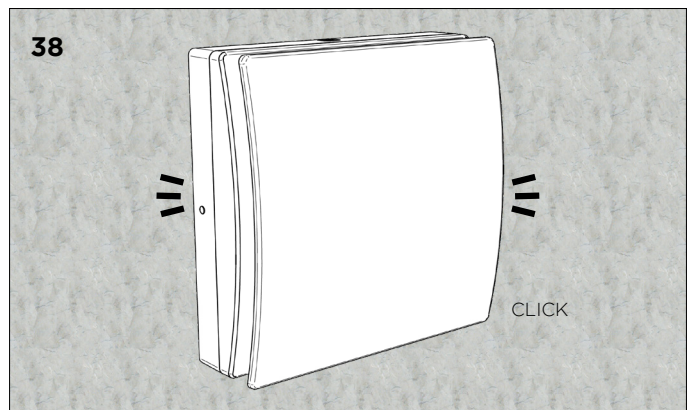

The unit will click together when seated correctly.

## REMOTE CONTROLLER WALL MOUNTING

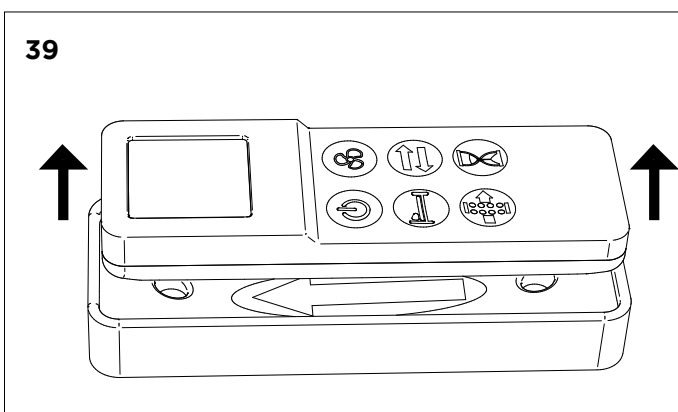

Remove the remote from the rear base.

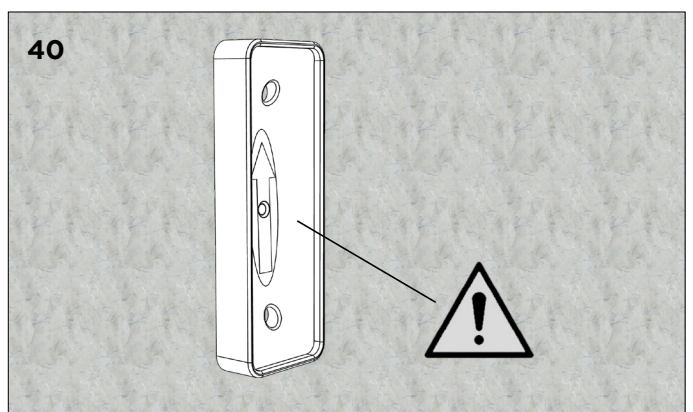

Ensure the base is mounted the correct way up.

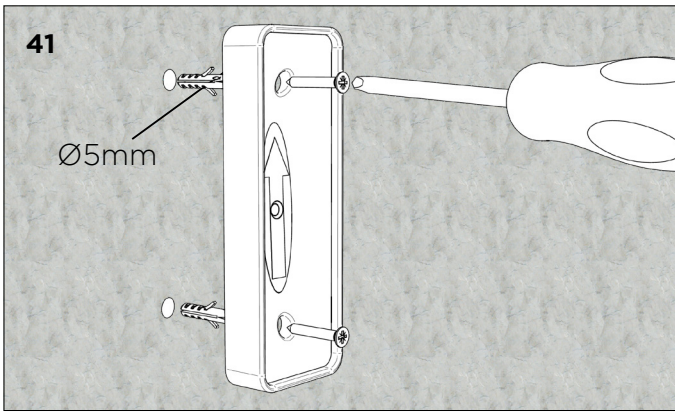

Drill two holes as per the image. Use the supplied fixings to mount the base. Some surface types may require other fixing types (not supplied).

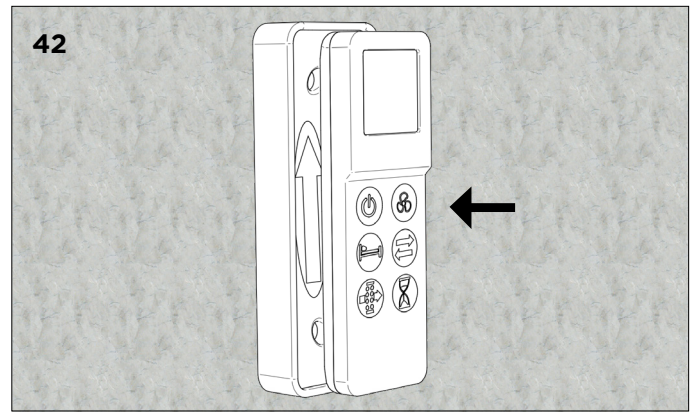

Locate the remote into the base.

## EXTERNAL GRILLE

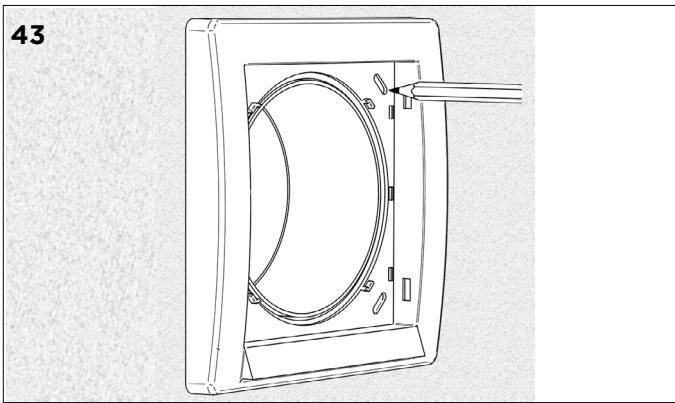

Hold the grille in place and mark the holes.

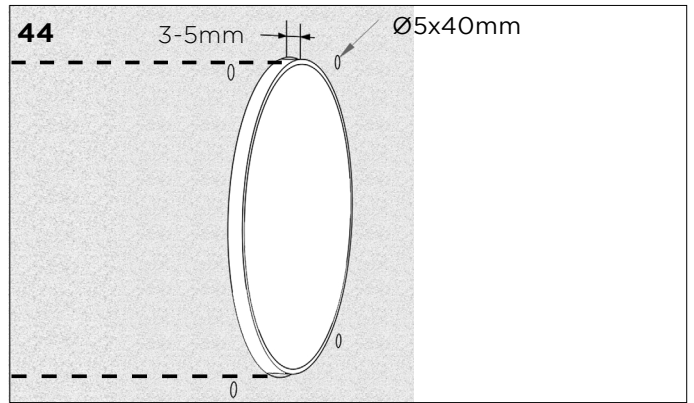

Drill the 4 x fixing holes. For optimum performance of the unit, ensure the ducting also protrudes 3-5mm from the wall surface.

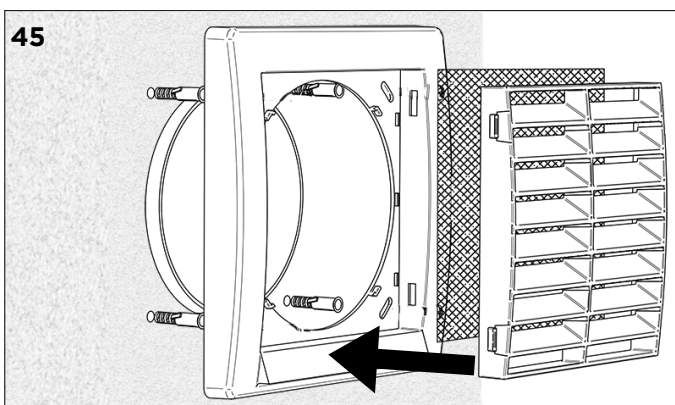

Use the supplied fixings to screw the base back. Then inset the mesh and finally click the fascia in place. Please note, depending on the mounting surface, alternative fixings may be required (not supplied).

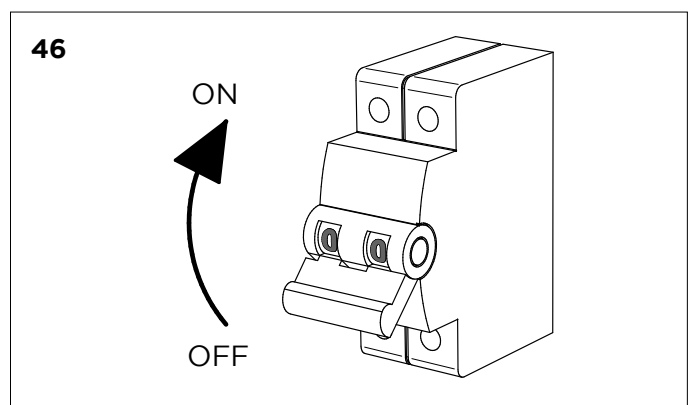

Energise the unit and check operation is correct.

# MAINTENANCE

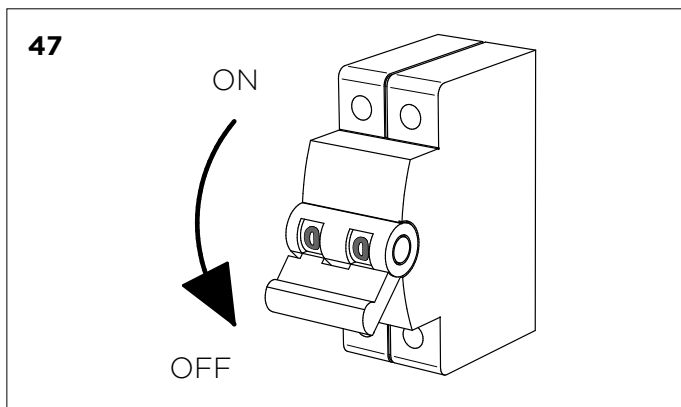

Isolate the electrical connection to the unit.

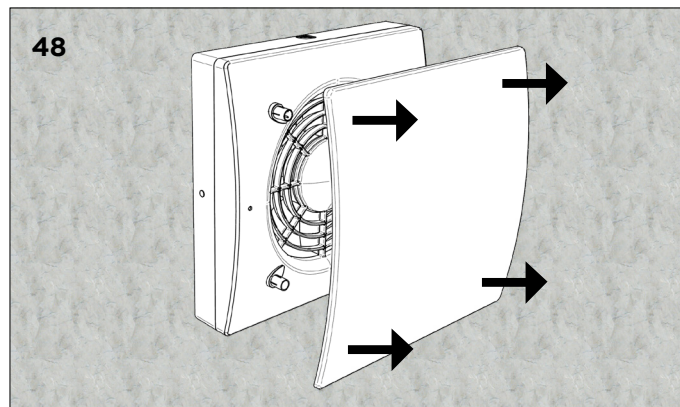

Remove the front face plate from the unit.

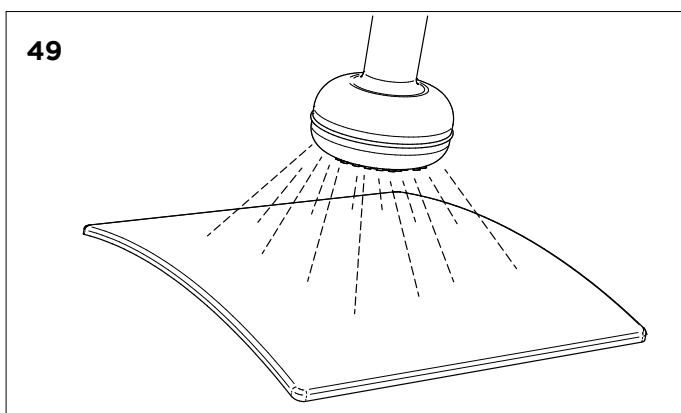

Wash the front face plate.

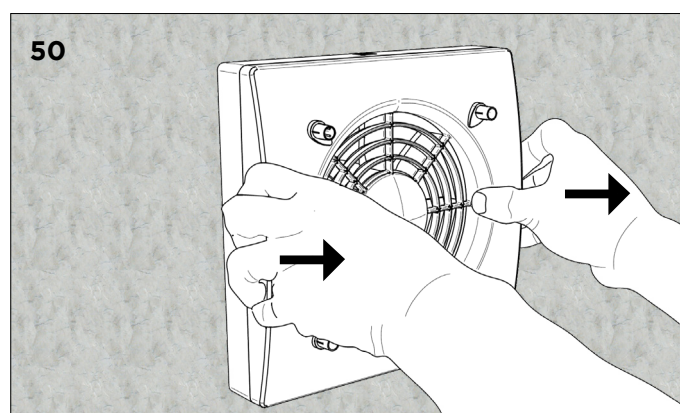

Remove the fan from the magnetic base.

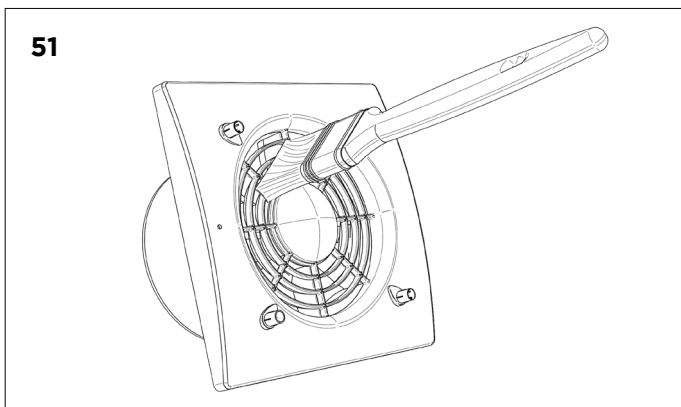

Remove any dirt from the unit with a dry, soft bristled brush.

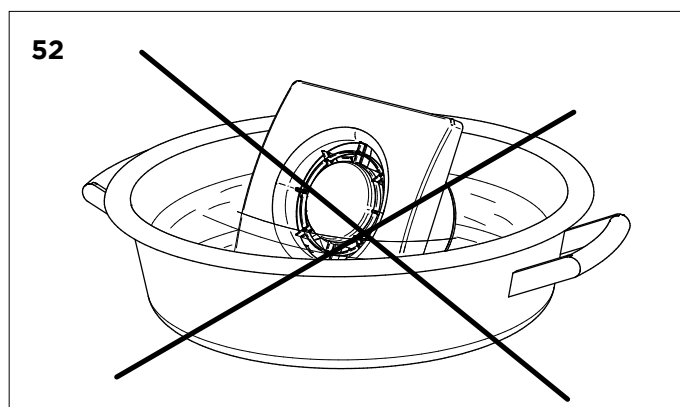

Do not submerge the unit or get it wet.



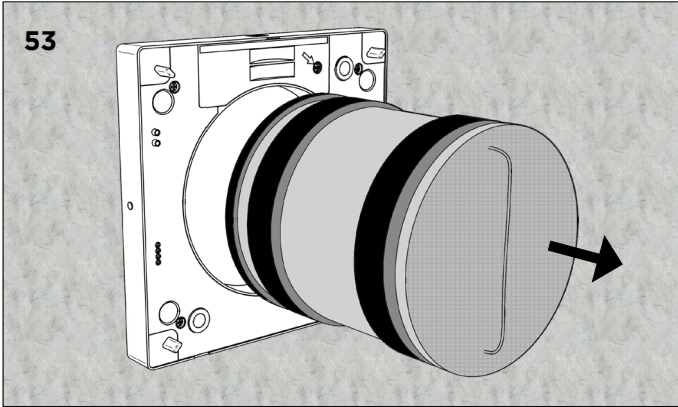

Remove the heat recovery core and filter assembly.

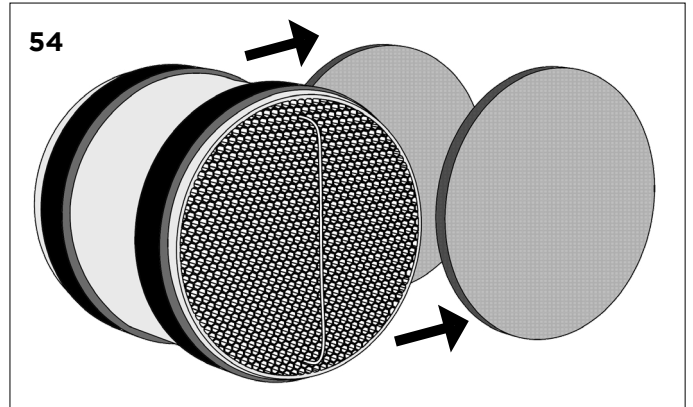

Remove the filters from the heat recovery core.

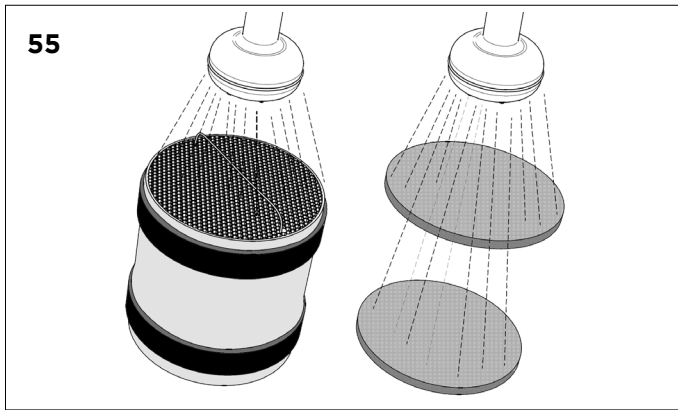

Wash the heat recovery core and filters thoroughly.

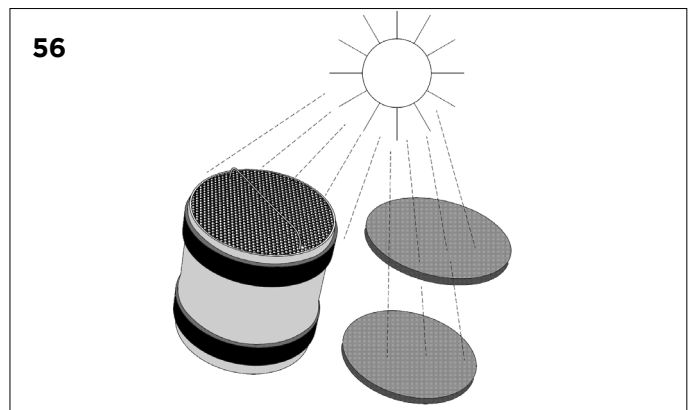

Dry the heat recovery core and filters thoroughly.

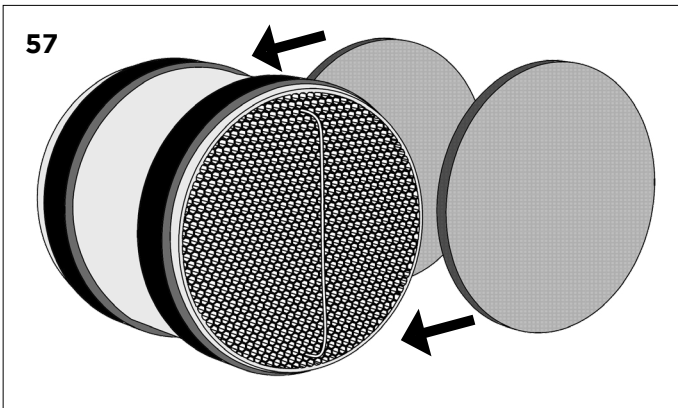

Add the filters back to the heat recovery core.

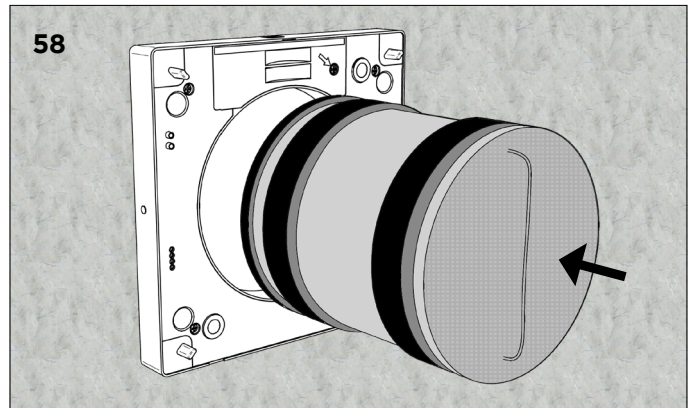

Insert the heat recovery core and filter assembly back into the duct.

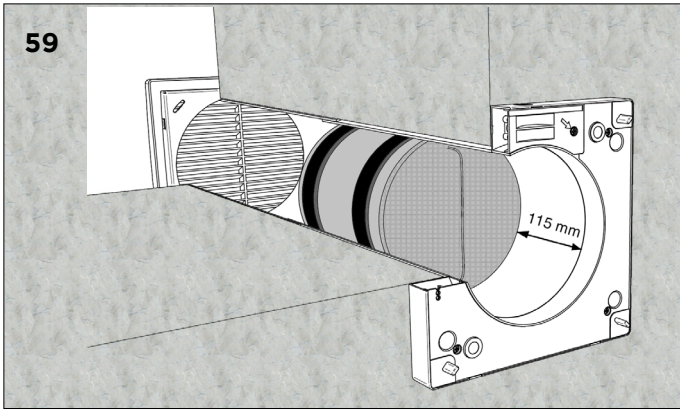

The exchanger should be seated in the ducting at the depth shown.

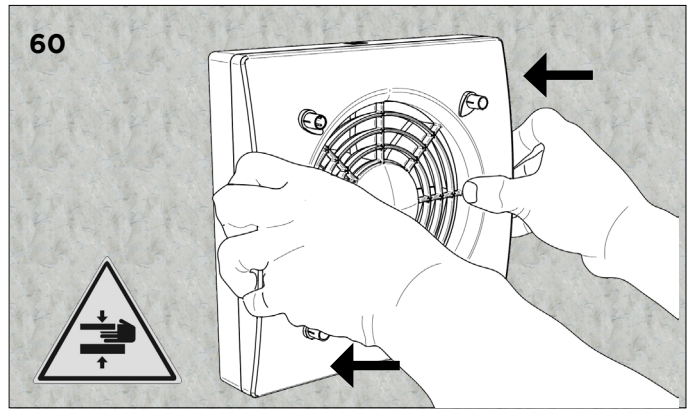

Re-attach the magnetic front cover. Be careful to ensure no body parts are between the 2 parts.

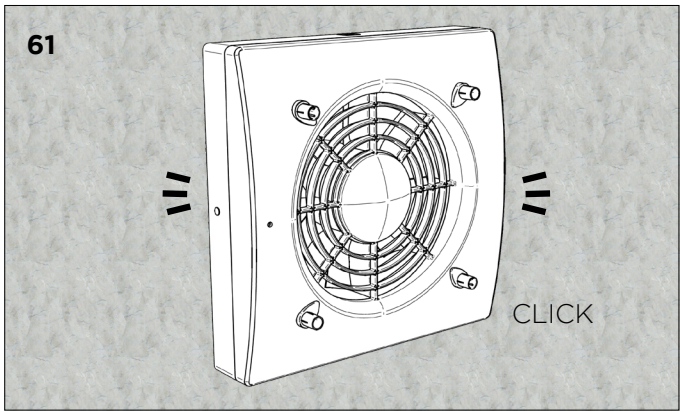

The unit will click together when seated correctly.

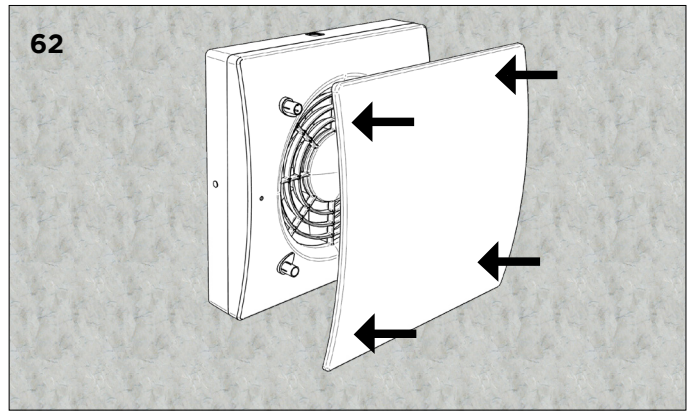

Re-attach the face plate when dry.

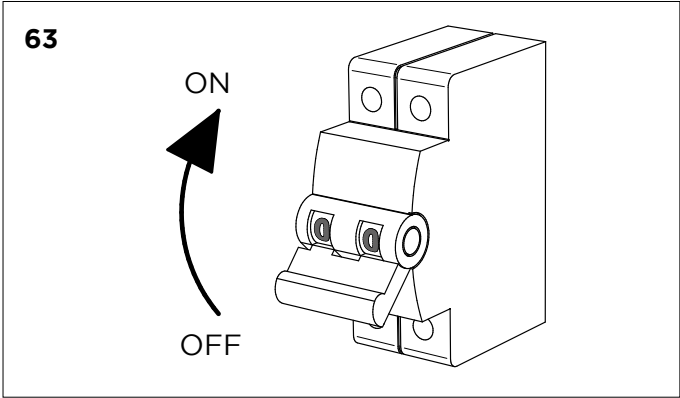

Energise the unit and check operation is correct.

# MAINTENANCE/CLEANING REGISTER

FILTER  
CLEANING

FILTER  
REPLACEMENT

HEAT  
EXCHANGER  
CLEANING

---

DATE

---

DATE

---

DATE

---

DATE

---

DATE

---

DATE

---

DATE

---

DATE

---

## ErP DIRECTIVE - REGULATIONS 1253/2014 - 1254/2014

a) Mark	-	ELTA TRADE	
b) Model	-	<b>DEXA HR 100 Plus+</b>	<b>DEXA HR 150 Plus+</b>
c) SEC class	-	A	
c1) SEC warm climates -	kWh	-17	-18.1
c2) SEC average climates	kWh	-40.6	-41.6
c3) SEC cold climates	kWh	-81.8	-82.8
Energy label	-	Yes	
d) Unit typology	-	Residential - bidirectional	
e) Type of drive	-	Multi-speed drive	
f) Type of Heat Recovery System	-	Heat recovery	
g) Thermal efficiency of heat recovery	%	74	
h) Maximum flow rate	m <sup>3</sup> /h	25	60
i) Electric power input at maximum flow rate	W	3.5	6
j) Sound power level (L <sub>WA</sub> )	dB(A)	39	40
k) Reference flow rate	m <sup>3</sup> /h	18	41
l) Reference pressure difference	Pa	10	10
m) Specific power input (SPI)	W/m <sup>3</sup> /h	0.139	0.080
n1) Control factor	-	0.65	0.65
n2) Control typology	-	Local demand control	
o1) Maximum internal leakage rate	%	N/A	
o2) Maximum external leakage rate	%	1	
p1) Internal mixing rate	%	N/A	
p2) External mixing rate	%	N/A	
q) Visual filter warning	-	N/A	
r) Instructions to install regulated grilles	-	N/A	
s) Internet address for pre/disassembly instructions	-	<a href="http://www.eltatrade.co.uk">www.eltatrade.co.uk</a>	
t) Airflow sensitivity to pressure variations	%	N/A	
u) Indoor/outdoor air tightness	m <sup>3</sup> /h	18	50
v1) AEC - Annual electricity consumption - warm climates	kWh	1	0.6
v2) AEC - Annual electricity consumption - average climates	kWh	1	0.6
v3) AEC - Annual electricity consumption - cold climates	kWh	1	0.6
w1) AHS - Annual heating saved - warm climates	kWh	19.5	
w2) AHS - Annual heating saved - average climates	kWh	43.1	
w3) Annual heating saved - cold climates	kWh	84.3	

01384 275771

info@eltatrade.co.uk

**www.eltatrade.co.uk**



# NEED A HAND SELECTING THE RIGHT FAN?

**At [eltatrade.co.uk](http://eltatrade.co.uk), we have a selection tool to help you or your customer choose the correct ventilation solution.**

You can also find your local stockist and see our full product range & accessories.

**FIND US ON SOCIAL MEDIA  
FOR PRODUCT RELEASES,  
COMPETITIONS & MORE!**

**@eltatradeuk**

01384 275771  
[info@eltatrade.co.uk](mailto:info@eltatrade.co.uk)  
[www.eltatrade.co.uk](http://www.eltatrade.co.uk)

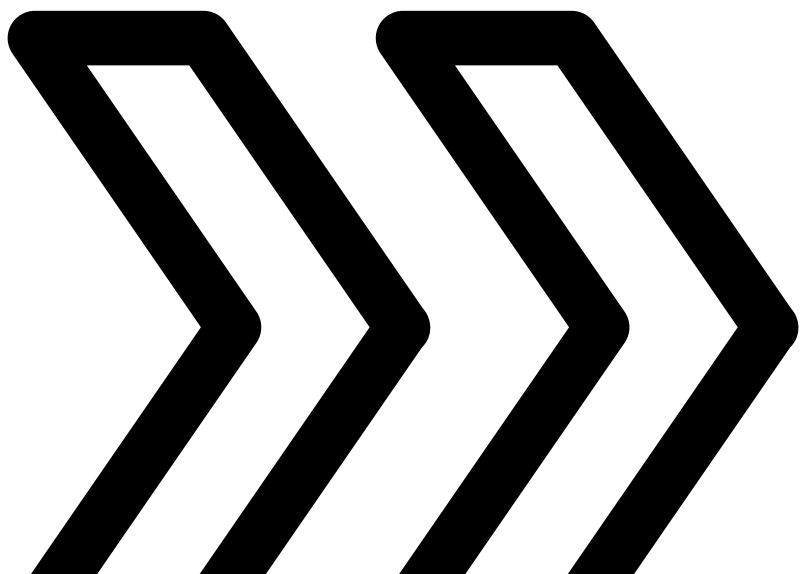



## WARRANTY

Our 5 year warranty is provided only to customers who purchased directly from us. If you purchased elsewhere then please contact them directly and they will let you know their warranty procedure. Our warranty covers repair or replacement of defective goods only. It does not cover any labour costs associated with defective product or component removal or installation, nor does it cover the cost of sending goods back to us for inspection. Our warranty is subject to storage, installation, commissioning, inspection and maintenance having been carried out in accordance with our Installation and Maintenance Instructions (supplied with each product) and which are also available to view, save or print from our website.

Scan the QR code or visit [www.eltatrade.co.uk/warranty](http://www.eltatrade.co.uk/warranty) to view further warranty information.

---



## DISPOSAL AND RECYCLING

Information on disposal of units at the end of life.

This product complies with EU Directive 2002/96/EC. The symbol of the crossed-out dustbin indicates that this product must be collected separately from other waste at the end of its life. The user must, therefore, dispose of the product in question at suitable electronic and electro-technical waste disposal collection centres, or else send the product back to the retailer when purchasing a new, equivalent type device.

Separate collection of decommissioned equipment for recycling, treatment and environmentally compatible disposal helps to prevent negative effects on the environment and on health and promotes the recycling of the materials that make up the equipment.

Improper disposal of the product by the user may result in administrative sanctions as provided by law.

---

**ELTA** >>>  
**TRADE**

Elta Trade is brought to you by Elta Fans Ltd. 46 Third Avenue,  
Kingswinford, West Midlands, DY6 7US. Manufactured in Italy.

01384 275771

info@eltatrade.co.uk

[www.eltatrade.co.uk](http://www.eltatrade.co.uk)

A MEMBER OF  ELTA  
GROUP



## DEXA HR Plus+ USER GUIDE

**NOTE: The installer should go through the user guide with the home occupants and leave this with them for their reference.**

### WHAT IS A DEXA HR?

DEXA HR Plus+ is a single alternate flow decentralised (single point) residential heat recovery unit, also called a push & pull unit, installed in “habitable rooms” in your home such as living rooms and bedrooms.

### HOW DOES IT WORK?

The fan is designed to work on a continuous basis by extracting stale air in your home from the habitable room it is installed in, then bringing air into the habitable room from outside. “Pulling” air out, and “pushing” air in. Heat from the air being removed is used to warm the air being brought in. It is likely that there will be a pair of fans in your house working together. How they work will depend on how the installer has set the fans to operate. Please see “Fan operation” confirmed by Installer.

### WHAT ARE THE BENEFITS?

The DEXA HR Plus+ can help improve the air quality within your home for the health and wellbeing of occupants as well as the building.

### HOW DO I OPERATE THE FAN?

Your DEXA HR Plus+ will have been set up by the Installer to operate via the infra-red remote controller, further information can be found within Installation & Maintenance manual which is available to download from our website.

### DOES IT NEED SERVICING?

The fan filter and heat exchanger core need to be serviced regularly to maintain optimum performance in line with the instructions in the Installation & Maintenance manual which is available to download from our website.

### HOW MUCH DOES IT COST TO RUN?

There are several variables that can determine the annual electrical running costs of the DEXA HR Plus+, however, at typical electricity costs as of June 2023, you should expect the fan to cost between £2-3 per year to run under normal conditions.

### WHAT IF I THINK THERE IS A PROBLEM WITH THE FAN?

If you are a tenant, please report it to your landlord. If you are not, please contact the company you purchased the fan from.

### IMPORTANT NOTE

DEXA HR Plus+ fans are designed to run continuously. The power supply to the fan should only be disconnected if a fault is detected or suspected or when the fan is being maintained. Prolonged and/ or repeated power interruption can create a health and safety risk and invalidate the fan warranty.



## DEXA HR Plus+ USER GUIDE

### FAN OPERATION

The fan is fully automatic and will continuously remove stale air and replace with outside air in the room it is installed in, settings can be adjusted by the infra-red controller. Further information can be found in the Installation & Maintenance manual which is available to download from our website or by scanning the QR code below.



Scan the QR code for product and warranty information.