



PC6BG - STEEL MANHOLE COVER

KEY FEATURES

- Intergrated lifting handles
- Moulded grouting flange
- Recommended for Driveways
- Galvanised Steel Cover to BS EN 1461:2017



PC6BG - Specifications

Product Weight (Kg)	6.5
Clear Opening	600 x 450
Overall Dimensions	663 x 513 x 30
Cover Material	Mild Steel to EN 10346 2015 DD11
Frame Material	Polypropylene (Grade AP9)
Load Rating	5 tonne GPW
Load Rating Data	12.5kN held for 30 seconds
FACTA Clauses	7.0, 7.2, 7.2.1, 7.2.3
Application	Driveway loading
Locking	None

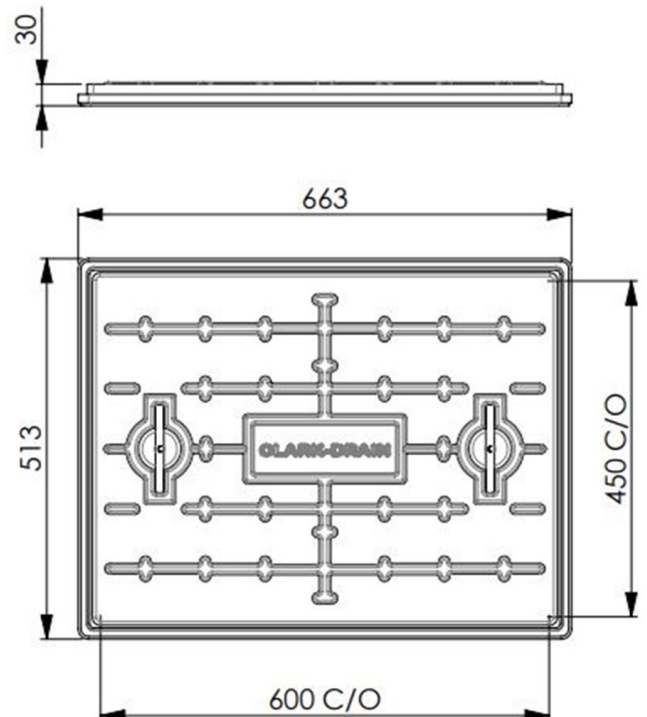

PC6BG/V0.1/09-12-2022