

WMS

Polystorm Lite and Polystorm

Installation Guide

Water Management Solutions

Installation Guidelines

Installation



The following section outlines site best practise for the installation of Polystorm Lite and Polystorm.



Installation for Attenuation Systems

5. Installation

5.1 Installation details

5.1.1 Health and Safety

Under the Construction (Design and Management) Regulations 2007, unless they are a domestic client, all parties involved in construction or building work have legal duties. These include:

Clients

- Check competence and resources of all appointees
- Ensure there are suitable management arrangements for the project welfare facilities
- Allow sufficient time and resources for all stages
- Provide pre-construction information to designers and contractors

Designers

- Eliminate hazards and reduce risks during design
- Provide information about remaining risks

Contractors

- Plan, manage and monitor own work and that of workers
- Check competence of all their appointees and workers
- Train own employees
- Provide information to their workers
- Comply with the specific requirements in Part 4 of the Regulations
- Ensure there are adequate welfare facilities for workers

It should be noted that additional legal duties are imposed where construction work is notifiable.

All installation activities should be carried out observing the requirements of The Health and Safety at Work Etc. Act 1974; and The Management of Health and Safety at Work Regulations 1999.

Polystorm Benefits for CDM Compliance

Storage applications using Polystorm Water Management Systems are actually beneficial to CDM compliance. This is because the system

avoids or reduces several risks associated with the construction of traditional storage tanks which can involve deep excavations and construction of large engineered structures. Specific advantages of Polystorm in this respect are:

- Individual Polystorm components are lightweight – making it easier for individual lifting of Polystorm cells.
- Installation of Polystorm is quick – so open excavation time is minimised and high numbers of manpower and machinery is reduced.

5.1.2 Risk Assessment

Contractors are required to submit a method statement which includes a methodology for installation and risk assessment for the work to be carried out.

5.1.3 Site Guidance

Good Practice Guide

The following are good practice principles for the handling and storage of all Polystorm cells on site:

- Store units away from direct sources of heat including sunlight for excessive periods
- Place packs of cells on level ground:
DO NOT stack filled pallets on site
- Store loose individual cells
NO MORE THAN 5 cells high
- Ensure a well positioned and secure stand for platform issued to remove the top layer of Polystorm cells from the pallet
- Although Polystorm cells contain an inhibitor giving ultra violet resistance for up to 6 months, avoid prolonged storage in direct sunlight
- DO NOT store cells near fuel bowsers, fuel tanks or any other solvents
- Although Polystorm cells are very robust and resistant to damage when handled normally, store in locations where impacts from vehicles and site plant will be avoided
- Ensure Polystorm cells are kept clean at all times

- Broken/cracked cells should not be installed. Broken/cracked cells should be recycled wherever possible
- Individual Polystorm Lite cells weigh 7kg and Polystorm 9kg so they can normally be safely lifted on site in accordance with current manual handling regulations.
- Avoid walking on the geosynthetic membrane to reduce risk of puncturing or tearing the textile
- Care must be taken when placing the cells into the excavation
- Install 1st layer of cells to minimise walking on the geomembrane textile

5.1.4 Floatation

When placed below the ground water table as an attenuation system (i.e. wrapped in a geomembrane) there is a risk that the buoyancy of a tank may cause it to float. This can be prevented by placing a sufficient weight of soil on top of the tank to counteract the upward forces. Our Technical Team can assist with groundwater calculations. Please contact Polypipe WMS technical support team. Also see section 4.

5.1.5 Excavation and Preparation

Excavate to the required plan dimensions and level, ensuring that the excavation orientation will allow easy installation of connecting pipework. Consideration should be given to maintaining construction plant access for reinstating around the installed Polystorm cells.

Ensure that the ground bearing capacity at the formation level is sufficient for the proposed operational loads. The base of the excavation should be smooth and level, free of large or sharp stones and soft spots to avoid punctures or tears of the geomembrane. Any soft spots should be excavated and replaced with suitable compacted granular material.

Place and compact a minimum 100mm thick layer of bedding material (typically coarse sand). If required, line the base and sides of the excavation with a protective geotextile before placement of the impermeable geomembrane. Excavation should be carried out in accordance with BS6031, paying particular attention to safety procedures.

5.1.6 Handling and Installation

All materials used should be checked before and after installation for any damage such as punctures or tears to the membrane.

The type of geosynthetic material used to encapsulate the Polystorm cells will determine the installation requirements. Please note the following information is generic and advice from the geosynthetic manufacturer should be sought to ensure that the appropriate protective measures are taken to comply with any proprietary requirements.

Physical Properties		
Thickness	Min 0.75 to 1.0mm	ASTM D5199
Density	900 kg/m ³	ASTM D1505
Mechanical Properties		
Tensile strength, at yield	Min 1600kN/m ²	ASTM D4885
Elongation at break	>500%	ASTM D4885
Puncture resistance	Min 170N	ASTM D4833
Tear resistance	Min 67N	ASTM D1004 Die C
Impact resistance	Min 15 Joules	ASTM 3998 mod
Stress crack resistance	Min 200 hrs	ASTM D5391 (SP-NCTL)
Permeability coefficient	Max 2.0 x 10 ⁻¹²	ASTM D
pH	Resistant to all naturally occurring soil acids and alkalis	
Chemical/biological resistance	Resistance to all substances found to naturally occur in soils and rainwater. Detailed information would need to be provided to geomembrane manufacturer in instances of contaminated land.	

Table 5-1 Impermeable Geomembrane

Before cells are installed a geomembrane should be laid over the subgrade level. Positioning of sheeting is undertaken by machinery or hand. After unrolling the sheeting, its position is adjusted so that a suitable overlap is achieved for the welding process. Before welding, the sheet must be checked for any damage including punctures or tears. If damage has occurred re-patch the damaged area with additional geomembrane material and weld over damaged area. Ensure the damaged area is overlapped by a minimum of 400mm.

Joint each sheet of geomembrane together according to the suppliers' recommendations.

Installation for Attenuation Systems

Polystorm Cell Installation

Before proceeding with the installation please ensure you carefully read and understand the Good Practise Guidelines stated earlier in the document.

Ensure cells are arranged so that they are in the correct alignment with the adjoining pipework. Wherever possible, minimise the amount of walking on the geomembrane to reduce the chances of punctures or tears to the material by laying the first layer of cells.

5.1.7 Connecting Polystorm Cells

Place the Polystorm cells on the geomembrane in accordance with the construction drawings. Ensure the Polystorm cells are abut and the corners align with each other. During installation, Polystorm cells should be securely connected using clips and shear connectors. Clips and shear connectors are supplied in sealed polythene bags of 60 and 30.

Clip Connectors

Polypipe clips connect horizontally adjacent units.

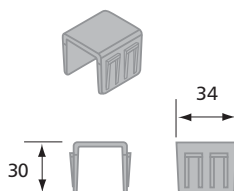

Shear Connector

Vertical connections are formed with the Polypipe shear connector.

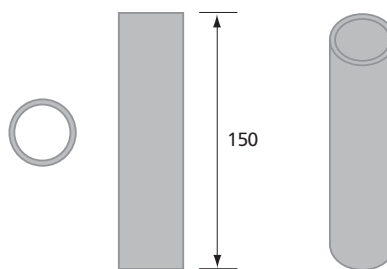

Figure 5-2 Clips and shear details

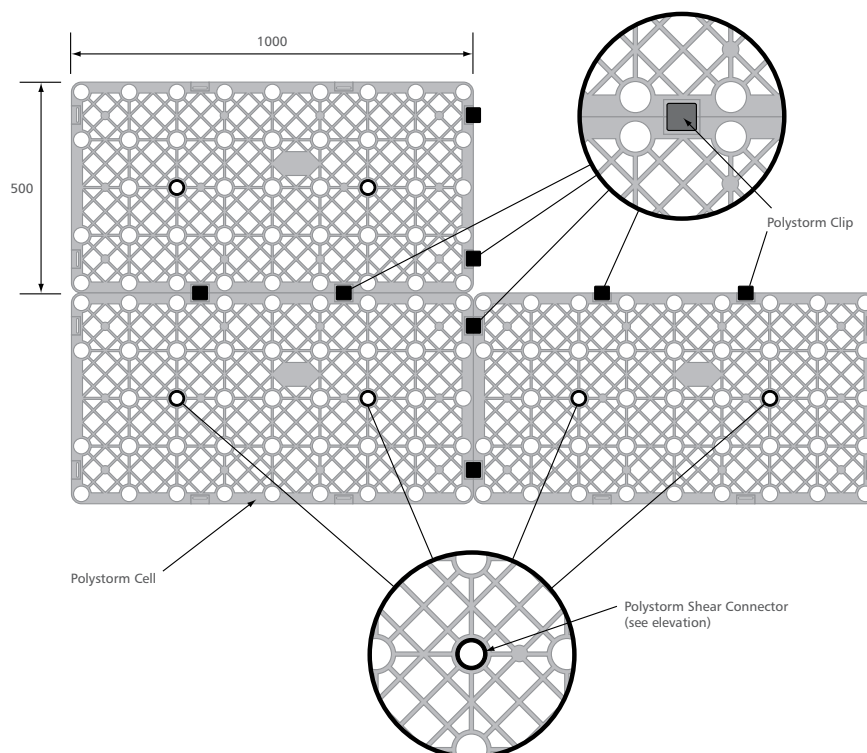

Figure 5-3 Location points for clips and shears

Shear Connector Installation

Insert shear connectors into Polystorm cell as shown. Ensure the shear connector is fully inserted before mounting the Polystorm cell.

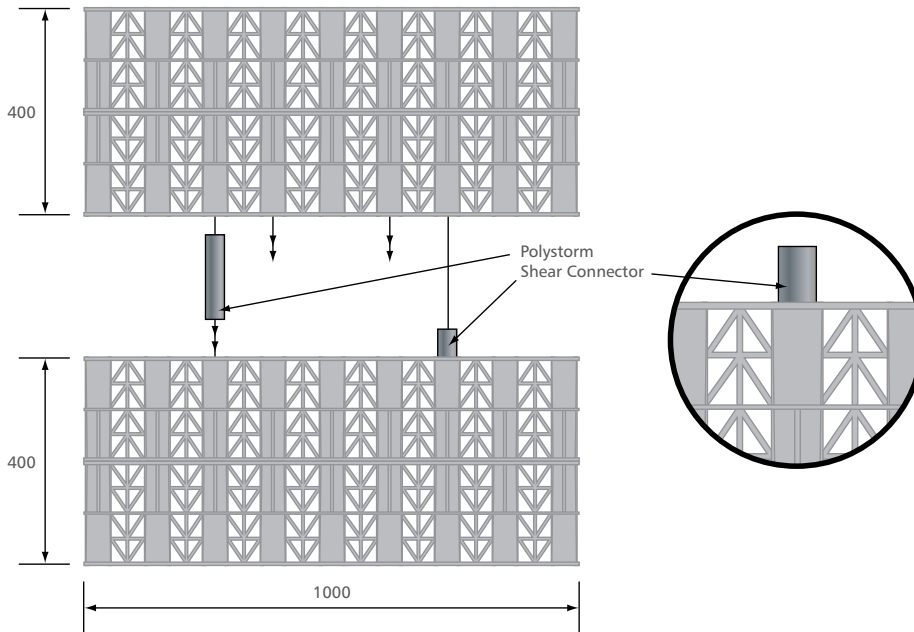

Figure 5-4 Shear connector installation

Clip connector installation

Polystorm cells are adjacently connected by clipping the two units together.

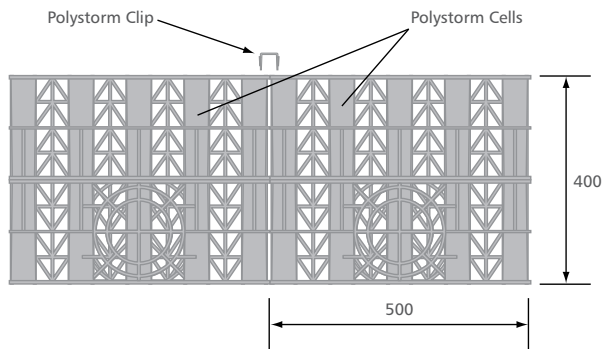

Figure 5-5 Clip connector installation

Installation for Attenuation Systems

5.2 Connections

Types of connections 160mm – 300mm (direct to cells)

160mm EN 1401-1 pipes connect directly into the convenient knock-out incorporated in the end of each cell. Connection to 110mm EN 1401-1 pipes or other products is accommodated through the use of standard Polypipe adapters. Polystorm cells are also available with either a 225mm or 300mm fabricated Ridgidrain pipe connection.

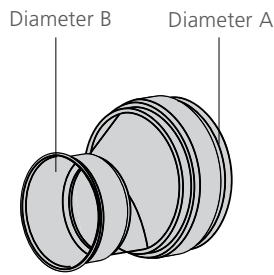

Figure 5-6 160/110mm invert level reducer

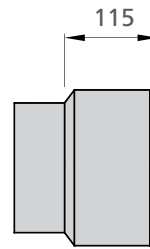

Figure 5-7 160mm diameter adaptor

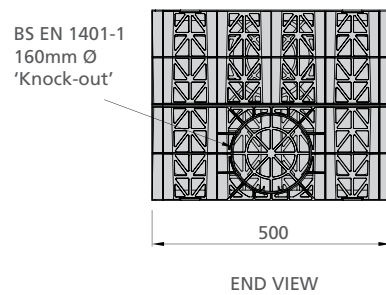

Figure 5-8 Polystorm cell 160mm diameter knockout

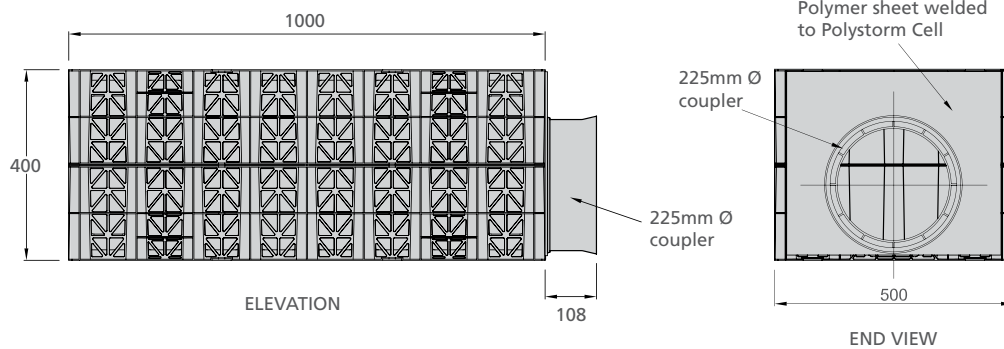

Figure 5-9 Fabricated Polystorm cell allowing 225mm diameter pipe connection

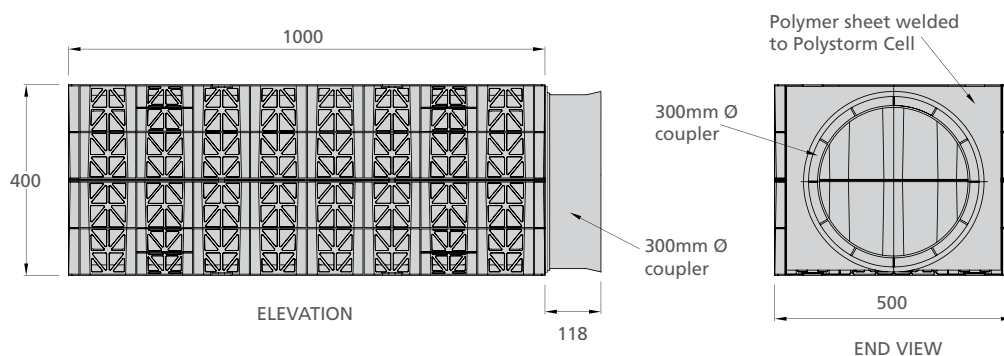

Figure 5-10 Fabricated Polystorm cell allowing 300mm diameter pipe connection

Types of connections 450mm – 600mm (direct to cells)

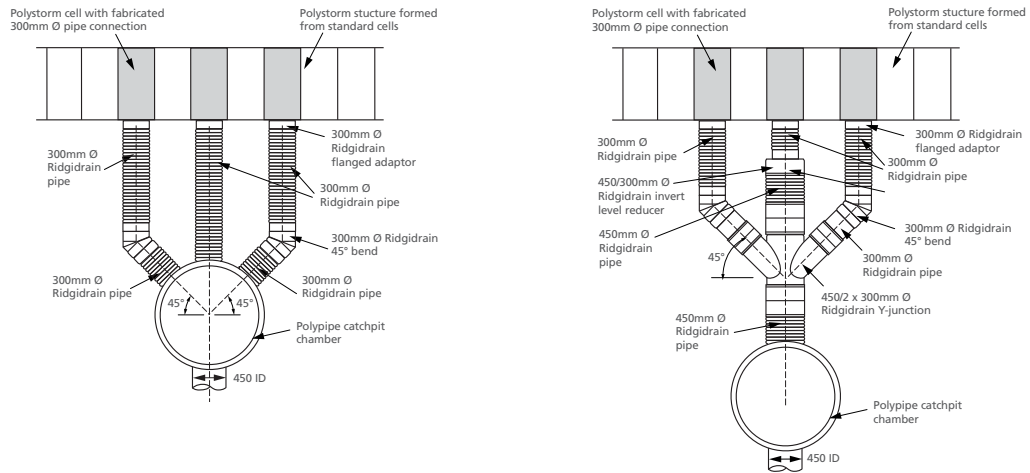

Figure 5-11 Typical Polystorm 450mm inlet manifold detail **Figure 5-12** Typical Polystorm 450mm inlet manifold detail

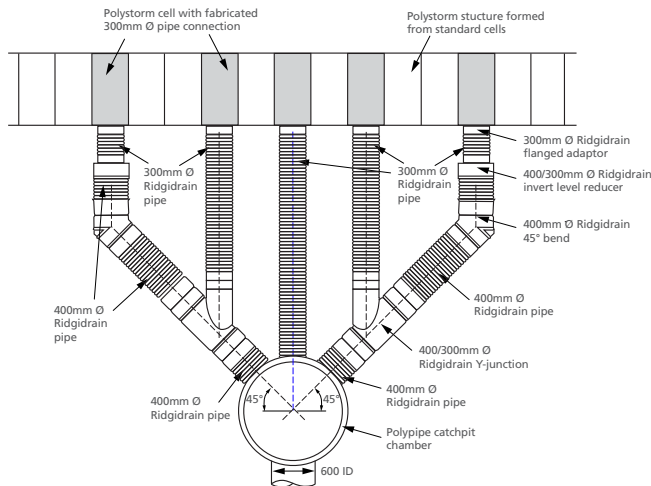

Figure 5-13 Typical Polystorm manifold detail

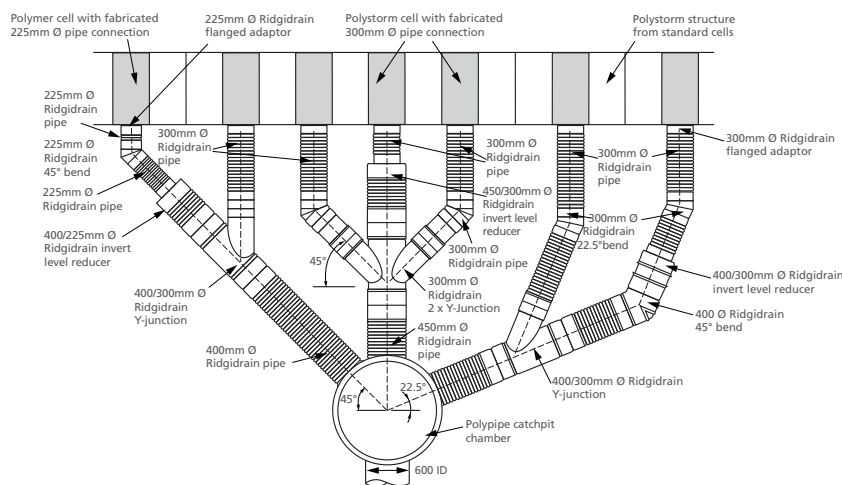

Figure 5-14 Typical Polystorm 600mm inlet manifold detail

Note: For inlets larger than 600mm please contact Polypipe WMS technical team.

Please also visit www.polypipewms.co.uk for downloadable Auto CAD files of the illustrations above.

Installation for Attenuation Systems

5.3 Ventilation

Every attenuation tank requires at least one vent to avoid stagnant water. An infiltration tank does not need a vent. Large attenuation tanks need a vent for every 7500m² of drained catchment area.

Figure 5-15 shows a vertical vent pipe with a cowl (SCV40). Figure 5-16 shows a horizontal vent pipe that connects to a catchpit.

5.3.1 Air vent connection and installation

Polystorm attenuation structures will require ventilation to ensure maximum hydraulic performance and avoid placing additional stress on the encapsulating geomembrane. Ensure vents are protected from damage during construction.

Attach a 110/160mm flange adaptor to a Polystorm cell from the top layer using cable ties on all four corners of the adaptor base and seal geomembrane around the flange, the same way as making an inlet or outlet connection and seal. Insert a 110/160mm dia vertical vent pipe into the flange and make connection.

Large attenuation tanks need a vent for every 7500m² of drained catchment area. A vent has a minimum size of 100mm diameter.

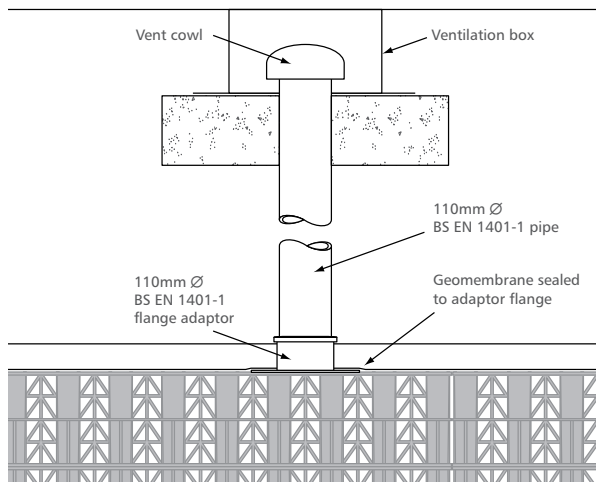

An alternative vertical vent pipe detail is available. Please call the Polypipe WMS technical support team.

Figure 5-15 Vertical vent pipe with cowl

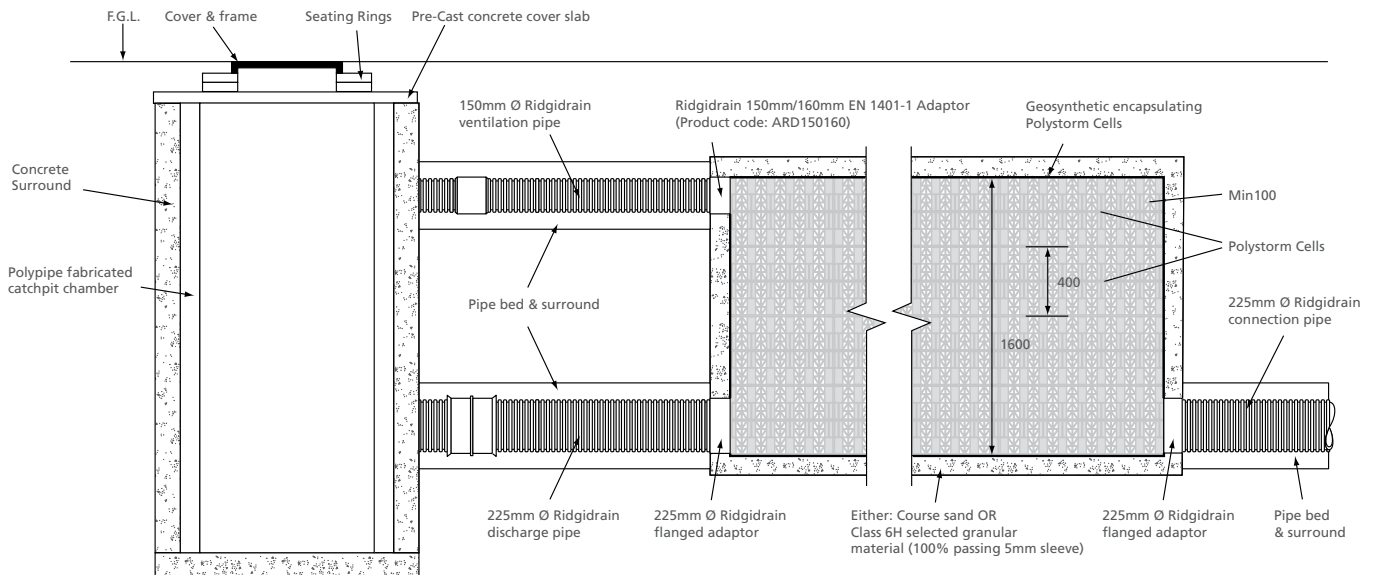

Figure 5-16 Horizontal vent pipe

5.3.2 Inlet and outlet connections and installations

A flange adaptor is attached at both the inlet and outlet points as this gives a flat surface for the membrane to be attached to. The flange adaptor will require a hole punching in each corner of the base. Ensure the flange adaptor is fastened securely to the cell using cable ties. Once the adaptor has been secured, insert the pipe and seal connection.



Sealing and Testing Connections

All pipes entering and leaving the structure must be sealed in accordance to the contractor's method statement. Ensure the geomembrane around all connection areas are clean and free from moisture before sealing. All sealing equipment should be tested at the start of each day to ensure consistency is maintained throughout the installation of the structure.

The inlet and outlet connections need a bung inserted into the hole to prevent siltation and water entering the structure whilst installation is carried out.

Once the connections have been sealed, testing should be carried out to check for leaks. This procedure should be carried out in accordance to the contractor's method statement. All testing equipment should be tested at the start of each day.

For advice on procedures for testing joints refer to CIRIA SP 124 – Barriers, liners and cover systems for containment and control of land contamination.

Encasing Geotextile

Complete the geosynthetic encapsulation of the entire Polystorm structure, forming joints where appropriate. Re-examine the geomembrane and/or geotextiles for damage and joint integrity. Avoid walking on the geosynthetic as this may cause punctures or tears to the material. The equipment used to form joints must be tested at the start of each day to ensure consistency is maintained throughout the process. For advice on procedures for testing joints refer to CIRIA SP 124 – barriers, liners and cover systems for containment and control of land contamination.

5.3.3 Lateral backfilling

Backfill around the sides of the encapsulated units, forming a 100mm thick layer of coarse sand or Class 6H selected granular material immediately adjacent to the cells.

Where required, remaining excavated areas around the units should be backfilled with Class 6N or 6P selected granular material, in accordance with MCHW, Volume 1, or similarly approved specification.

5.3.4 Cover backfilling

Backfill around the sides of the encapsulated cells, forming a 100mm thick layer of coarse sand or Class 6H selected granular material immediately adjacent to the cells.

Where required, remaining excavated areas around the units should be backfilled with Class 6N or 6P selected granular material, in accordance with MCHW, Volume 1 or similarly approved specification.

Final backfilling of the installation and surfacing is dependent on the expected operational loads. (NB Compaction plant over and immediately adjacent to the Polystorm cells shall not exceed 2300 kg/m width).

Above the wrapped Polystorm cells, place and lightly compact a minimum 100mm thick layer of either coarse sand or Class 6H selected granular material (with 100% passing the 5mm sieve), in accordance with MCHW, Volume 1, Series 600.

Installation for Attenuation Systems

5.3.5 Field conditions (e.g. landscaped areas)

The backfill material that lies within 300mm above the Polystorm cells should be free from particles exceeding 40mm in diameter, in accordance with Class 8 material to Series 600, Volume 1, MCHW. Final backfilling up to finished ground level may be achieved using selected as-dug material. Backfill material should be placed and compacted in layers no greater than 300mm, or in compliance with the approved specification.

5.3.6 Lightly trafficked (e.g. restricted access car park)

Backfill with Class 1 or 2 material in accordance with MCHW, Volume 1, Series 600. Backfill material should be placed and compacted in layers not greater than 150mm. Where the Polystorm cells are installed beneath a paved area, the pavement sub-base may form part of the backfill material provided that minimum cover depths are maintained. Complete pavement construction or landscaping over the Polystorm system.

5.3.7 Heavy trafficked (e.g. roads used by HGV's)

Contact Polypipe WMS technical support team for further information and guidance.

5.3.8 Inspection

After installation and prior to handover, any silt collection chambers or control manholes should be examined to ensure they are free from debris. All chambers and manholes require the insertion of bungs at the inlet and outlet to prevent siltation during construction. Bungs should then be removed at commissioning.



Installation for Soakaway Systems

5.4 Typical Installation Procedure - Soakaway

5.4.1 Excavation and preparation

Place and compact a 100mm thick bedding layer of either coarse sand or Class 6H selected granular material (with 100% passing the 5mm sieve), in accordance with the Manual of Contract Documents for Highway Works (MCHW), Volume 1, Series 600. Install the permeable geotextiles, forming joints in accordance with the manufacturer's recommendations, making an allowance for the connecting pipework or adapters.

5.4.2 Geotextile layer (Permeable)

The type of geosynthetic material used to encapsulate the Polystorm cells will determine the installation requirements. Please note the following information is generic and advice from the geosynthetic manufacturer should be sought to ensure that the appropriate protective measures are taken to comply with any proprietary requirements.

Physical Properties		
Material	Typically Polypropylene/Polyethylene	
Mass	Min 125g/m ²	EN 965
Mechanical Properties		
CBR puncture resistance	Min 1500 N	EN ISO 12236
Peak tensile strength	Min 8kN/m ²	EN ISO 10319
Hydraulic properties		
Water flow rate normal to plane	Min 100 l/m ² .s (@ 50mm Head	EN ISO 11058
Pore size O90	Typically 100 µm	EN ISO 12956
pH	Resistance to all naturally occurring soil acids and alkalis	
Chemical/biological resistance	Resistance to all substances found to naturally occur in soils and rainwater. Detailed information would need to be provided to geosynthetic manufacturer in instances of contaminated land.	

Table 5-7 Permeable Geotextile

All joints should be sealed, using proprietary methods recommended by the manufacturer. Please refer to CIRIA SP 124 – Barriers, liners and cover systems for containment and control of land contamination, for advice on seam testing procedures.

Before the cells are installed the geotextile should be laid over the subgrade level. The sheet of geotextile should be large enough such that it can overlap over the edge of the modules by 200mm.

5.4.3 Polystorm cell installation

Place the Polystorm cells on the geotextile in accordance with the construction drawings and Polypipe connection details. Ensure cells are arranged so that they are in the correct alignment with the adjoining pipework (see pages 50-51).

5.4.3.1 Shear connection

Vertical connections are formed with the Polypipe shear connector (see pages 50-51).

5.4.3.2 Clip connectors

Polypipe clips connect horizontally adjacent cells (see pages 50-51).

5.4.4 Polystorm cell connections

Pipe Connections

160mm EN 1401-1 pipes connect directly into the convenient knock-out incorporated in the end of each cell. Connection to 110mm EN 1401-1 pipes or other products is accommodated through the use of standard Polypipe adapters. Polystorm cells are also available with either a 225mm or 300mm fabricated Ridgidrain pipe connection (see pages 50-51).

5.4.5 Encasing geotextile

Complete the geosynthetic encapsulation of the entire Polystorm structure, forming joints where appropriate. Re-examine the geomembrane and/or geotextile for damage and joint integrity.

5.4.6 Lateral backfilling

Backfill around the sides of the encapsulated cells, forming a 100mm thick layer of coarse sand or Class 6H selected granular material immediately adjacent to the cells.

Where required, remaining excavated areas around the cells should be backfilled with Class 6N or 6P selected granular material, in accordance with MCHW, Volume 1, or similarly approved specification.

5.4.7 Cover backfilling

Backfill around the sides of the encapsulated cells, forming a 100mm thick layer of coarse sand or Class 6H selected granular material immediately adjacent to the cells.

Where required, remaining excavated areas around the cells should be backfilled with Class 6N or 6P selected granular material, in accordance with MCHW, Volume 1, or similarly approved specification.

Above the wrapped Polystorm cells, place and lightly compact a minimum 100mm thick layer of either coarse sand or Class 6H selected granular material (with 100% passing the 5mm sieve), in accordance with MCHW, Volume 1, Series 600.

Final backfilling of the installation and surfacing is dependent on the expected operational loads. (NB Compaction plant over and immediately adjacent to the Polystorm cells shall not exceed 2300 kg/m width).

5.4.7.1 Field conditions (e.g. landscaped areas)

The backfill material that lies within 300mm above the Polystorm cells should be free from particles exceeding 40mm in diameter, in accordance with Class 8 material to Series 600, Volume 1, MCHW. Final backfilling up to finished ground level may be achieved using selected as-dug material. Backfill material should be placed and compacted in layers no greater than 300mm, or in compliance with the approved specification.

5.4.7.2 Lightly trafficked (e.g. restricted access car park)

Backfill with Class 1 or 2 material in accordance with MCHW, Volume 1, Series 600. Backfill material should be placed and compacted in layers not greater than 150mm. Where the Polystorm cells are installed beneath a paved area, the pavement sub-base may form part of the backfill material provided that minimum cover depths are maintained. Complete pavement construction or landscaping over the Polystorm system.

5.4.8 Inspection

After installation and prior to handover, any silt collection chambers or control manholes should be examined to ensure they are free from debris or contamination.