

## Goliath Super 250 - Automatic Sump Pump

The Goliath Super® is a robust sump pump made of stainless steel plate and fibre-reinforced plastic, resistant to corrosion. It also features a vortex impeller giving 30mm solids handling. The maximum depth of submersion is 10m.

### Features:

- Discharge can be vertical or horizontal
- Double mechanical seal
- Automatic as standard but can be converted to manual upon request

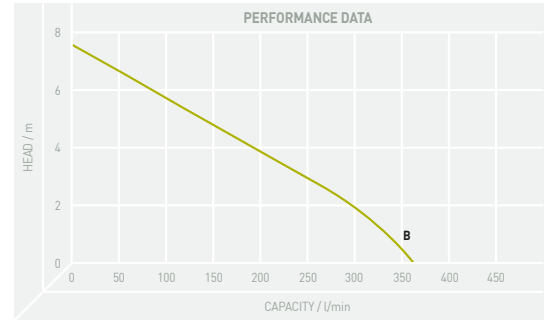

## TECHNICAL SPECIFICATION

PUMP TYPE	PRODUCT CODE	CURVE	OUTPUT		DISCHARGE		MAXIMUM		FREE PASSAGE mm	CABLE	WEIGHT kg
			kW		mm	inch	HEAD M	CAPACITY LPM			
Goliath Super 250 230V (Manual)	PM/GOLIATHS2/1	/B	0.25		50	2	7.5	360	30	5	8.5
Goliath Super 250 230V (A-Float)	PM/GOLIATHS2/1-A	/B	0.25		50	2	7.5	360	30	5	8.5
Goliath Super 250 230V (F-Float)	PM/GOLIATHS2/1-F	/B	0.25		50	2	7.5	360	30	5	8.5
Goliath Super 250 230V (Z-Float)	PM/GOLIATHS2/1-Z	/B	0.25		50	2	7.5	360	30	5	8.5

## PARTS AND MATERIAL LISTS

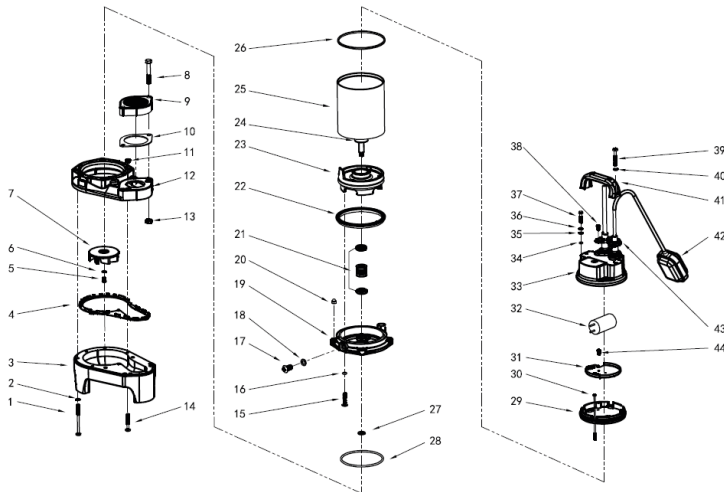

No.	PART	QTY	No.	PART	QTY	No.	PART	QTY	No.	PART	QTY
1	Screw	4	12	Casing	1	23	Lower Motor Cover	1	34	O Ring	4
2	Washer	4	13	Nut	2	24	Bearing	2	35	Washer	4
3	Casing Lower	1	14	Screw	2	25	Motor	1	36	Spring Washer	4
4	Casing Seal	1	15	Screw	4	26	Upper Motor Seal	1	37	Hex Bolt	4
5	Screw	1	16	O Ring	4	27	Oil Plug Seal	1	38	Screw	4
6	Washer	1	17	Screw	1	28	O Ring	1	39	Screw	2
7	Impeller	1	18	Seal Washer	1	29	Upper Motor Cover	1	40	O Ring	2
8	Screw	2	19	Oil Casing	1	30	Screw	1	41	Handle	1
9	Screwed Flange	1	20	Cap Nut	4	31	Capacitor Spacer	1	42	Float Switch	1
10	Flange Seal	1	21	Mechanical Seal	1	32	Capacitor	1	43	Cable Gland Cover	2
11	Nut	2	22	Lower Seal Ring	1	33	Capacitor Cover	1	44	Screw	1

## DIMENSIONAL DRAWINGS

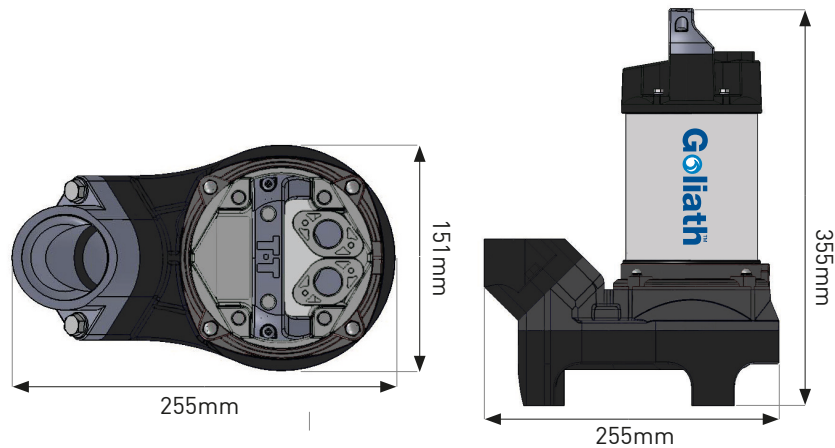

## Recommended Sump Sizes and Float Switch Stop/Start Levels

A-FLOAT	RECOMMENDED SUMP SIZES FOR GOLIATH A-FLOAT mm		FLOAT SWITCH STOP/START LEVELS A-FLOAT (APPROX)	
	SUMP SHAPE	230V		230V
		310L x 270W x 430H	FLOAT ACTIVATION HEIGHT	230mm
		310D x 430H	FLOAT DEACTIVATION HEIGHT	90mm
		310L x 310W x 430H		
Z-FLOAT	RECOMMENDED SUMP SIZES FOR GOLIATH Z-FLOAT mm		FLOAT SWITCH STOP/START LEVELS Z-FLOAT (APPROX)	
	SUMP SHAPE	230V		230V
		310L x 270W x 420H	FLOAT ACTIVATION HEIGHT	290mm
		310D x 420H	FLOAT DEACTIVATION HEIGHT	190mm
		310L x 310W x 420H		
F-FLOAT	RECOMMENDED SUMP SIZES FOR GOLIATH F-FLOAT mm		FLOAT SWITCH STOP/START LEVELS F-FLOAT (APPROX)	
	SUMP SHAPE	230V		230V
		Not Advised, Use Square	FLOAT ACTIVATION HEIGHT	62cm (cable length at 32cm)
		600D x 820H	FLOAT DEACTIVATION HEIGHT	30cm (cable length at 32cm)
		600L x 600W x 820H		