

Pluto Micro Package Pumping Station

Planet pluto micro

Below & Above Ground Pump Station

User Information Manual



Contents

Introduction & Contact Information	3
About the Pluto Micro Package Pumping Station	4
Required tools for gaskets and cable gland installation	4
Safety Instructions	5
Transportation & Storage	7
Site Design	8
Product Receipt Check	8
Prior to Installation (Below Ground)	8
Preparation	9
Excavation	9
Concrete Specification	9
Below Ground Civil Installation Guide	10
Above Ground Installation	12
Control Systems	14
Float Switch Adjustment	14
Electric Connections	14
Commissioning of your Pumping Station	14
Operation, Maintenance & Safety Procedures	15
Hygiene	15
Regular Maintenance	16
Fault Finding	17
Disposal	18
After Sales Support	18
Dimensions & Parts	19
Turret Assembly Exploded View	20
Notes & Cable Gland Entry Template	21

Introduction

Thank you for selecting the **T-T Pluto Micro Package Pumping Station** range. This Operation and Maintenance manual contains important product information, including the correct method of civil installation and precautions regarding its safe use.

When installed and maintained correctly, your pumping station should provide reliable operation over a long period. It is essential that regular maintenance, and if necessary, prompt repairs are carried out to ensure satisfactory and reliable operation. Therefore we urge you to use the T-T PUMPS Service Agreement system, for continued attention to your pumping station by T-T PUMPS Service Engineers.

Our products are manufactured to high standards at economic prices and are complemented by our warranty, which covers all items for 12 months from date of delivery or the date of commissioning, when T-T PUMPS is employed to commission the pumping station. We offer full after sales support for your pumping station for spares, repairs and servicing. For warranty claims please contact our Pumping Stations Department who will always give you a prompt response.

If this instruction manual should become lost or damaged, please ask your nearest dealer or agent for a replacement copy.

All inquiries made to T-T PUMPS in connection with this equipment should include these details, please complete upon receipt of your pumping system:-

T-T Pumps Contract Number:

Original Purchasers Name:

Customer order Number:

Pump Chamber:

Pump Type:

About the Pluto Micro Package Pumping Station

Our Pluto Micro package pumping station has been developed to provide a compact, robust and cost-effective solution to larger, more expensive alternatives. They are an effective means for collecting and removing excess water and drainage.

The Pluto has been designed to suit a multitude of applications, including, but not limited to:

- Domestic Sewage situations
- Domestic Surface water situations
- Basement / Cavity Wall / Damp Drainage applications
- Small Domestic foul water applications, extensions, annexes etc
- Applications where access to mains drainage is not available via gravity means.

The tanks are constructed from polyethylene, whilst the internal pipework is generally made up of ABS pipework and fittings. Stainless steel ancillary items are also used to provide long-lasting, corrosion resistance and give a high quality finish.

These fully automatic, single pump units are designed and built for reliability, long life, and employs a high performance pump range that can be selected to meet your specific application.

The Pluto Micro pumping station can also be installed above ground, giving greater flexibility to refurbishment projects.

An optional extension turret kit can be provided to give greater flexibility for site adjustments and to give the pumps, and the tank greater frost protection by lowering the tank in external situations.

The access covers provided are suitable for pedestrian loading only.

Required tools for gaskets and cable gland installation

To install the DN110 inlet pipework gasket(s), the DN50 gasket(s) and if above ground, the electrical cable glands you will need the following equipment.



Cordless drill



125mm Hole Saw
DN110 Gasket(s)



64mm Hole Saw
(DN50 Gasket(s))



20mm Hole Saw
(Cable Glands, above ground version)

Safety Instructions.



This is a **SAFETY ALERT SYMBOL**. When you see this symbol on the pump or in the manual, look for one of the following signal words and be alert to the potential for personal injury or property damage.



Warns of hazards that **WILL** cause serious personal injury, death, or major property damage.



Warns of hazards that **CAN** cause serious personal injury, death, or major property damage.



Warns of hazards that **CAN** cause personal injury or property damage

Become thoroughly familiar with the instructions in the documents consigned with the pump. This will enable you to work in complete safety and to obtain the best performance the pump is able to offer.

The following instructions apply to the standard version of the electric pump operating in normal conditions. Special versions, shown by the product code, may not fully comply with the instructions herein [when necessary, the manual will be supplemented with additional information].

As it is our policy to continually improve our products, the data in the documentation and the product itself may be subject to modification without the manufacturer being obliged to give advance warning.



All electrical work must be performed by a qualified electrician to regulatory guidelines. Any queries should be directed to your local electrical inspector. Failure to follow regulatory guidelines and safety standards may result in personal injury or equipment damage. Failure to follow manufacturers installation instructions may result in electrical shock, fire hazard, personal injury or death, damaged equipment, provide unsatisfactory performance and may void manufacturer's warranty.

Disconnect and isolate electrical power before installing or servicing any electrical equipment. Many pumps are equipped with automatic thermal overload protection which may allow an overheated pump to restart unexpectedly.

Do not lift, carry, or hang pump by the electrical cables. Damage to the electrical cables can cause shock, burns or death.

Safety Instructions [cont.]

WARNING

Install the supply and connect the pump as per the regulatory guidelines.

The electrical supply voltage and phase must match all equipment requirements. Incorrect voltage or phase can cause fire, motor, and control damage, and voids the warranty.

Failure to permanently ground the pump, motor, and controls before connecting to power can cause shock, burns or death.

CAUTION

Where possible manual lifting should be avoided and mechanical lifting devices such as sack trucks or trolleys should be used whenever possible. However, due to the possible locations the Pluto Cellar Box can be installed, a minimum of two persons to position the system is recommended.

Please take note of the following important safety precautions:

- If the optional turret is ordered, lifting **must** be done by the tank neck, and **not** by the extension turret [if one supplied].
- Should the access cover frame become loose during transport (compression fit to tank) you may need to lubricate the seal on the frame to refit, as the tank opening may contract in cold weather due to the material used in the construction of the tank.
- Discharge connections **MUST** be correctly made to relevant fittings prior to use.
- All installation works must be carried out by competent trained person[s].
- Installers / maintainers should be aware of the latest manual handling advisories prior to use.
- Mechanical loading / unloading should be used where possible.
- Site / environment relevant personal protective equipment [PPE] should be worn and used while installing and maintaining the product.
- Access to the supplied equipment should be restricted to trained persons as much as reasonably practical to the site conditions and risks.

Any and all manual handling must follow the 'Manual Handling Operations Regulations 1992' and be carried out by trained, competent persons.

Transportation & Storage

The Pluto Micro Package Pumping Station will be delivered secured to a pallet and is supplied fully assembled, and ready to install. It should only be loaded/unloaded via suitable mechanical means. Once removed from the pallet, the Pluto can be moved, by two people, following manual handling regulations.

Please check inside the tank for loose items, such as the optional alarm system and any loose ancillary items ordered.

Check that the delivery is complete and undamaged. Any damage that is detected should be confirmed on the original consignment note and reported to us immediately. The Pluto chamber is moulded from polyethylene which gives the tank high strength and excellent durability. However it is of vital importance that great care is taken to prevent accidental damage to the chamber walls, arising from accidental blows from tools or concentrated pressure on the chamber walls.

Similarly, sharp corners or edges of bricks and stones should be avoided all times. Impact from a sharp object during the handling and/or installation of the product could fracture the tank wall. The chamber must only be lifted using certified lifting slings, and under no circumstances should the internal pipe connections or fittings be used as lifting points. If the optional extension neck is included, it is important that this is not used as a lifting point.

CAUTION

Structural damage to the tank resulting from the above will render the warranty void. When unloading, pay attention to weight and center of gravity of the pump station.

If the optional turret is ordered, lifting must be done by the tank neck, and not by the extension turret.

Store the product in a dry place, sheltered from the weather. All connections should be checked for tightness before and after transportation.

The submersible pump[s] must be handled with care. The free ends of the cables must never be immersed or wetted in any way.

All lifting equipment is to be correctly calibrated prior to use, this equipment is to be operated by trained individuals only, all lifting and manual handling should be done in accordance with the 'Manual Handling Operations Regulations 1992'.

Failure to do so may invalidate any claim.

Site Design

Initial planning can save a lot of time and effort in the later stages, and we suggest that you carefully consider the following points:-

1. Location of pumping station, usually at the lowest ground level on site. Will it be accessible for future service work?
2. Will the incoming pipework have sufficient gradient?
3. Will the inlet and rising main pipe work be sufficiently buried underground, in line with the pipe work manufacturer's recommendations?
4. Will the power supply be adequate and will the size of supply cable be sufficiently sized to allow for any voltage drop?
5. All necessary health and safety measures must be observed during the installation process of the pumping station.
6. Chamber and cover slab locations.

Product Receipt Check

Prior to your receipt of the Pluto Micro pumping station, all of the equipment has been subject to a full in-house, pre delivery inspection. This is to ensure that all of the components and parts are packed correctly and reach site safely.

On receipt of delivery, please ensure that the Polythene chamber is intact and has not been damaged in anyway. Please also check that the items you have received are in accordance with your order, as any claims for missing or lost items must be made within 24 hours of receipt.

A major items check-list makes up part of the delivery note for the goods; this lists the key items so that they may be thoroughly checked on delivery. Please note that any items included within the delivery notes that are not signed for will be deemed delivered and correct.

Should the access cover frame become dislodged from the tank opening during transport (compression fit)the seal may require lubrication prior to re-fitting.

Prior to Installation [Below Ground]

Please follow these simple checks prior to lifting and installing the Pluto Micro chamber:

- Complete a visual check of the unit for any visible signs of damage.
- Check that all fittings and attachments are secured and fastened.
- Ensure all excavations for the tank are safe for working around.
- Ensure base slab has been cast at the correct depth, is level and dry

We recommend that you engage the services of:-

- A competent civil engineer/ building contractor for the installation of your Pluto chamber in the ground and pipework connections.
- A competent electrical contractor is required for all electrical items and services including the provision of the power supply and the installation and connection of the pump and control cabling.



Preparation

All internal pipe work and valves will be supplied assembled inside the chamber prior to delivery. On some occasions, owing to the nature of the delivery method that we use, items such as the alarm system may be packed within the chamber. Please remove all such items prior to installation.

Excavation

All excavations should allow the placing and concrete backfilling of the chamber.

Check the incoming drain invert depth and the depth of the excavation allowing for a minimum 200mm thick concrete foundation to subsoil.

Check alignment of the required inlet socket[s] and cable duct with inlet pipework prior cutting any holes in the tank wall. Holes can be cut using a hole saw or similar, taking care not to further damage the tank walls.

Concrete Specification

Please refer to BS EN 206, BS 8500-1 & BS 8500-2, the two documents must be read in conjunction.

We strongly suggest that you employ the services of a ground condition surveyor to establish the quality of the ground that the system is to be installed into, and also to provide you with a recommendation as to the type of concrete pre-mix you should use. Below is a list of information that you may find beneficial:

RC25 pre-mixed concrete is the minimum specification of concrete with a slump class of S2 for type DC1 ground conditions. For ground conditions other than DC1, it is the responsibility of the site designer or appointed ground surveyor to recommend otherwise.

The concrete must be compacted thoroughly throughout the backfilling process to eliminate the chance of voids. Please avoid prolonged contact between the chamber wall and the concrete rammers used to avoid rammmer burns and damage to the chamber.

The site designer must also take into consideration the strength and condition of the ground for this type of installation, i.e peaty ground etc. The base of the excavation may require strengthening, also bearing in the mind the loading requirement from the cover level.

It is of vital importance that the excavation is kept dry throughout the installation process. For high ground water conditions, the use of drainage pumps will be required to keep the excavation dry. This is imperative, as the strength of the concrete backfill can be affected, resulting in irreparable damage to the chamber.

T-T PUMPS Ltd will not accept any liability for a damaged chamber which is the direct result of a poor concrete selection or installation. No claims will be considered unless a concrete certificate is provided by a certified pre-mix supplier.

Below Ground Civil Installation Guide

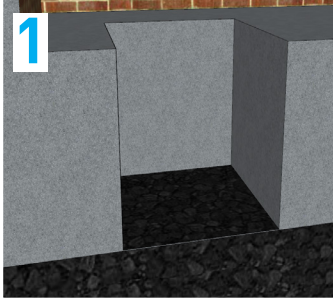

1
Excavate a hole to suit an area of 1000x1000mm, to a minimum depth of 855mm to accommodate a base slab.

A trench for the rising main, inlet pipes, cable duct and a vent pipe are also required.

Should the optional ext. turret be required, the hole should be a minimum 1250mm deep to accommodate the turret**

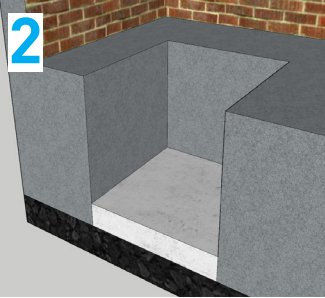

2
With the excavations complete, prepare the ground for the pouring of the base slab.

We recommend a minimum 200mm thick base to allow enough material for the fixing anchors to secure the tank.

Allow time for the base to fully set.

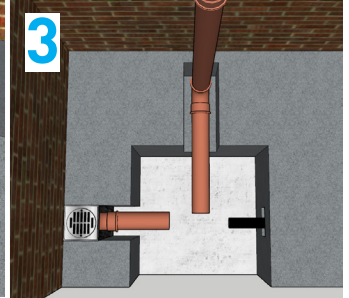

3
Lay the rising main, inlet pipes, cable ducts and the vent pipe where required to suit the site layout.

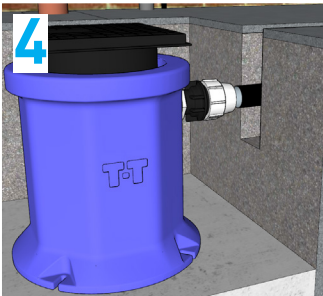

4
Place the tank in the hole and align the rising main with the tank outlet adaptor.

Mark the locations on the tank of all incoming pipes and ducts.

Mark the floor fixing points of the tank to align when fixing.



5
You will need to cut a Ø125mm hole in the tank for the Ø110mm inlet pipe sealing ring connections and a Ø64mm hole for the 2" cable duct/vent pipe. With the holes cut in the chamber, place back in the excavation and drill and fix the tank to the concrete slab.

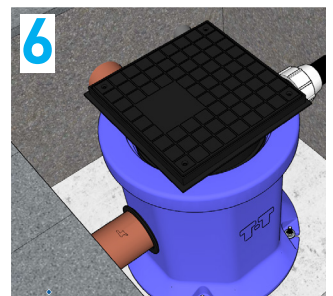

6
Connect the inlet pipe(s) through the seal (pipe may need some lubrication to slide through the seal). Ensure the pipe is supported to stop any movement and compromise the seal. Ensure the end of the pipe/ducts do not obstruct internal components - **max 10mm pipe length inside tank.**

Below Ground Civil Installation Guide [cont.]

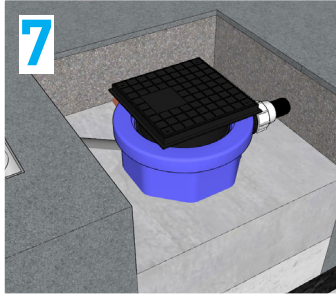

With the tank secured, pipes and ducts secured in place, and ensuring all cables are pulled through the cable ducts to the control panel, half fill the tank with clean water.

This will allow you to check for leaks, and allow you to start the concrete backfill wet pour.

The tank requires a minimum of 200mm concrete surround.

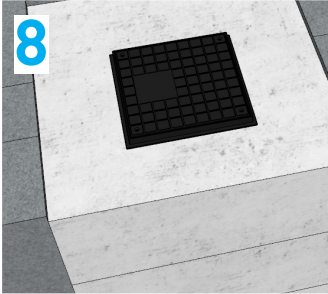

T-T recommend a maximum of 500mm concrete backfill per wet pour, ensuring the chamber is full of water.

When the final backfill has set, grout up the remaining opening to FFL and secure the access cover in the frame.

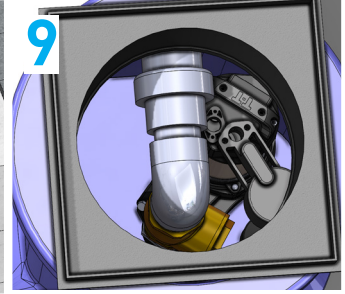

Ensure any float switches are hanging free within the tank and all cables pulled through to the motor control panel, ensure to leave enough the minimum amount of slack within the tank. Pull cables through locally for final electrical connections.

Connect the mains power to energise the supply and begin testing procedures.

Once testing has been successfully completed and the system can be commissioned.

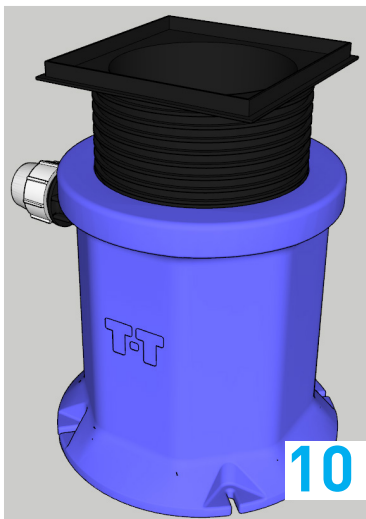

Optional Turret Installation

The Pluto Micro tank is supplied fully assembled, with all pumps and pipework in place upon delivery. Level control floats are also set up and a standard level arrangement set.

All cables are left coiled in the tank ready to be pulled through the cable ducts.

Lifting must be done by the tank neck and not the turret.

Thanks to the design of the Pluto Micro, multiple inlet pipes can be added to the tank, however, additional seals will need to be purchased.

Access covers provided are pedestrian loading only 3.5kN.

Above Ground Installation

The Pluto Micro system can be installed as an above ground pumping station, thanks to its robust design and seal system.

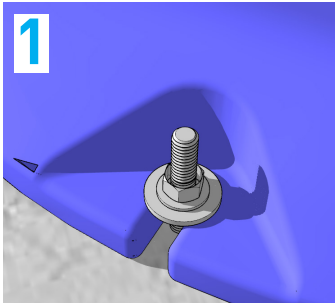

1
Situating the tank at the required location. Mark the slot locations on the floor to drill holes to suit M12 anchor bolts.

Secure the tank to the floor, taking care not to over-tighten the anchor bolts and damage the tank.

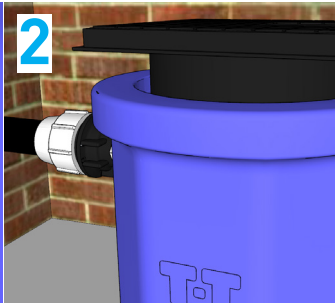

2
With the tank secured, connect the MDPE adaptor to the rising main pipe and ensure there is a good, tight seal, to prevent any leaks.

Rising main spec. should be $\varnothing 63\text{mm}$ O/D, $\varnothing 50\text{mm}$ I/D.

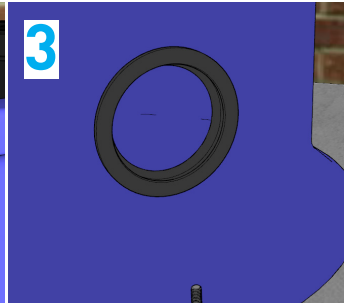

3
Mark the tank with the required inlet pipe position(s). Using a $\varnothing 125\text{mm}$ hole saw, drill the tank to suit the $\varnothing 110\text{mm}$ seal provided.

Only one $\varnothing 110\text{mm}$ seal is provided, additional can be purchased from T-T for multiple inlets.

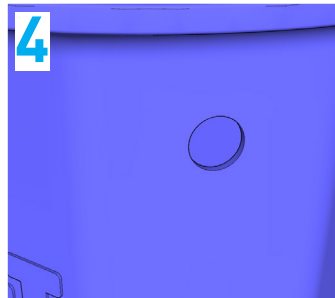

4
The Pluto tank will require a 2" pipe vented to atmosphere. Mark and drill the tank towards the top of the flat side area with a $\varnothing 64\text{mm}$ hole saw.

One $\varnothing 50\text{mm}$ seal is provided.

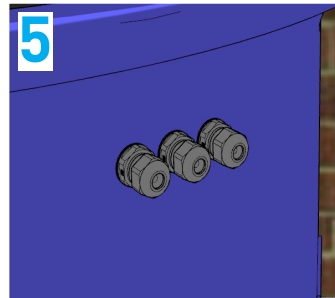

5
Pump and float cable entries need to be drilled through the tanks. Generally these will be M16 waterproof glands. Drill the tank to suit the location of the control panel. Depending on system spec. will determine gland numbers.

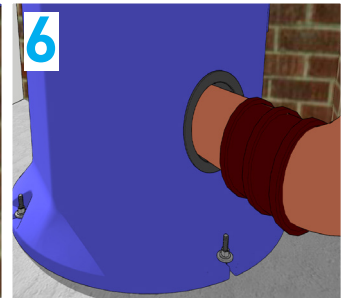

6
Connect the inlet pipes(s) through the seal (pipe may need some lubrication to slide through the seal). Ensure all pipes and ducts are supported to stop any movement and compromise the seal. **Max 10mm pipe length inside tank to prevent interference with float operation.**

Above Ground Installation [cont.]

A suitable power supply should be provided and correctly sized breaker for the submersible pump connection. Should the optional high level alarm system be taken, an suitable electrical connection will be required to suit also.



7 Mount the optional alarm system to the wall. The alarm system needs to be within 4m of the Pluto tank. The standard pump cable length supplied in 5m (longer cables can be supplied on request)

Pull cables through cable glands, and connect to the alarm system.



8 With the inlet pipe, vent pipe secured, connect the pump cable and optional alarm float connection to their associated yet isolated breakers.

Use a competent, qualified electrical contractor for this work.

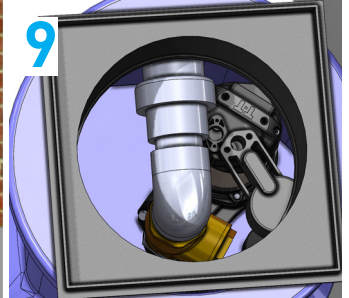

9 Ensure the float switch is clear of the side of the tank and all cables pulled through enough to leave minimum slack within the tank.

Slowly fill with clean water, to test the seals on the pipes are working and no leaks are evident.



10 Before finally testing the system, ensure the rising main is connected to the appropriate discharge point. With that checked, check the tank isolation valve is fully open to allow the clean water to pump away.

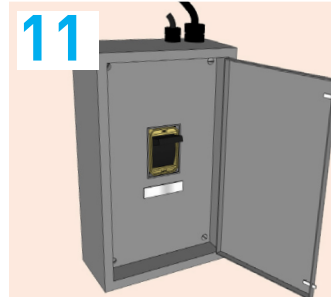

11 Connect the mains power to energise the supply and begin testing procedures.

Once testing has been successfully completed and the system can be commissioned.



12 Congratulations, your surface mounted pumping station has been installed successfully.

Control System

The system operates automatically via a pre-installed, pre-set level control float switch. Should the optional alarm system be used, via a second float switch which requires installation within the Pluto Micro chamber, in the event of a pump failure, you will be notified by an audible and visual alarm.

Electrical Connections

Please employ the services of a competent electrical engineer / contractor.

Our T-T Engineers may attend site to complete this task for you, if required. Please contact our Sales Department to discuss this if you have not already received our quotation.

Before attempting to make any electrical connections, please ensure that the pump[s] is in the chamber and the cable from the pump[s] is not trapped and is free. The pump and the float switch cables need to be pulled through the cable ducting on site and you must refer to the electrical wiring diagram supplied with the control system for the electrical installation.

Commissioning of your Pumping Station

Having satisfied yourself that all the connections are correct, a brief test run of the system is required as follows:

To test the pump on a single pump station, lift the duty float into its start position and you should feel that the pump is operational. Carry out this procedure for a few seconds only and then return the float switch back to its stop position to turn the pump off.

To test the high level alarm float switch, simply lift this float to its start position and it will operate the alarm features of the control panel.

Operation, Maintenance & Safety Procedures

Package pumping stations can be very hazardous, and appropriate working practices must be always followed. The instructions and information given in this manual are as explicit as reasonably practicable and both competence and expertise are necessary in the maintenance of the system.

To ensure reliable and trouble-free operation of the system, we strongly recommend that the servicing of the system is only undertaken by experienced and authorized personnel. The operation and maintenance of this system must be carried out in compliance with all current health, safety and welfare legislation.

Sewage pumping stations, where applicable, are safe in operation, however because of the media being pumped, gases such as methane and hydrogen sulphide can build up. It is therefore important that sensible precautions are taken.

Package Stations have been designed to be maintained from the outside of the chamber as the pump[s] and float switches are all fully removable from the chamber.

CAUTION

The following check list should help...

- Never work or maintain a sewage pumping station on your own.
- Isolate the electrical supply before working on a pumping station.
- Never enter the pump chamber under any circumstances unless fully qualified to do so, i.e., confined space trained, using appropriate safety equipment.
- Keep naked flames away from pumping stations.
- Never leave the pump chamber open or unattended.
- Always secure the access cover lid when leaving the pumping station.
- Never use a wander light in or around the pump chamber unless the light is intrinsically safe.
- The Plant/Equipment must not be used for work for which it is not design intended.

Hygiene

WARNING

When working on a live pumping station take sensible precautions about hygiene. Always wear protective overalls, gloves and footwear. When work is completed remove soiled clothing for laundering or disposal and always wash thoroughly.

Much of the equipment installed on this plant is designed to operate automatically and may start without warning. Before working on any item of the plant or equipment, ensure it is correctly, electrically and mechanically isolated.

Regular Maintenance - Sewage Applications

It is important that the pumping station is checked frequently, to ensure that it is in full working order and that there is not an excessive build-up of fats and materials.

If there is a build-up of fatty materials, pour a reasonable quantity of household detergent onto the affected area, leave for a little while and then hose down, repeat if necessary. This will ensure that the float switches and pumps operate freely without a build-up of fatty matter. In areas where large amounts of grease are expected, the fitting of a grease trap prior to the pumping station is recommended.

Fault Finding

SYMPTOM	POSSIBLE CAUSE	CORRECTIVE ACTION
Pump does not start	Check and rectify power supply, including check for excessive cable length or incorrect cable size causing voltage drop	Check and rectify power supply, including check for excessive cable length or incorrect cable size causing voltage drop
	Power not switched on at all points, or connections not secure	Check all switches and cable connections
	Fuse failed or circuit breaker operated	Check fuses / circuit breaker
	Motor fault	Investigate and rectify
	Cable damaged	Replace
	Pump impeller obstructed	Clear
	Level switches obstructed or at incorrect level	Check manual switching satisfactory [except on pumps with integral level switches]. Ensure level switches are correctly set to operate.
Pump starts and stops repeatedly	Level switches obstructed or at incorrect level	Clear or reset
	Power supply fault	Investigate and rectify, including check for voltage drop on starting
	Pump impeller obstructed	Clear or reset
	Non-return valve[s] obstructed or faulty, allowing back flow when pump stops.	Clear or repair/replace
Pump runs, but noisy or vibrates	Pump / impeller air locked	Release air
	Pump impeller worn or damaged, or pump shaft damaged	Investigate and replace as necessary
Pump runs but gives no output or reduced output	Discharge obstructed	Clear pipework
	Valve[s] partly or fully closed or obstructed	Open or clear valves
	Discharge leak in pumping chamber	Secure discharge connections
	Pump impeller obstructed	Clear
	Pump impeller worn	Replace
	Pump air locked	Release air
	Pump wrong rotation	Rectify electrical connections (3 phase motor only)
	Incorrect pump selection	Re-assess system
	Pump impeller obstructed	Clear
Pump runs, but noisy or vibrates	Pump/impeller air locked	Release air
	Pump impeller worn or damaged, or pump shaft damaged	Investigate and replace as necessary

Disposal



The Pluto tank is manufactured from virgin High-density Polyethylene, and the symbol displayed left and on the tank indicates it can be recycled.

HDPE is accepted at most recycling centres in the world, as it is one of the easiest plastic polymers to recycle. Most recycling companies will collect HDPE products and take these to large facilities to be processed.

Please check with your local authority for recycling capabilities.

Please refer to the specific pump manual for disposal instructions.

After Sales Support

Your product should have a long and reliable life if it is cared for and maintained correctly. We would strongly recommend that the pumping system is serviced thoroughly at least every six months. This should be undertaken by component electrical/mechanical engineers.

T-T Pumps offers a full after sales service, including our Service Agreement scheme. This can give you peace of mind, allowing you to achieve maximum reliability and efficiency from your product.

For full details of our Service Agreement scheme, please contact our Service Department who will be pleased to provide you with a quotation **+44 (0)1630 647200**.

Dimensional Details & Parts

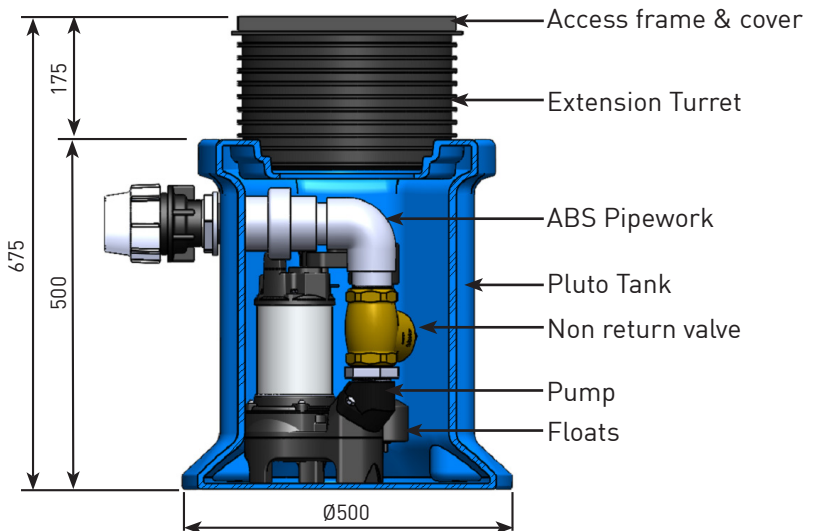
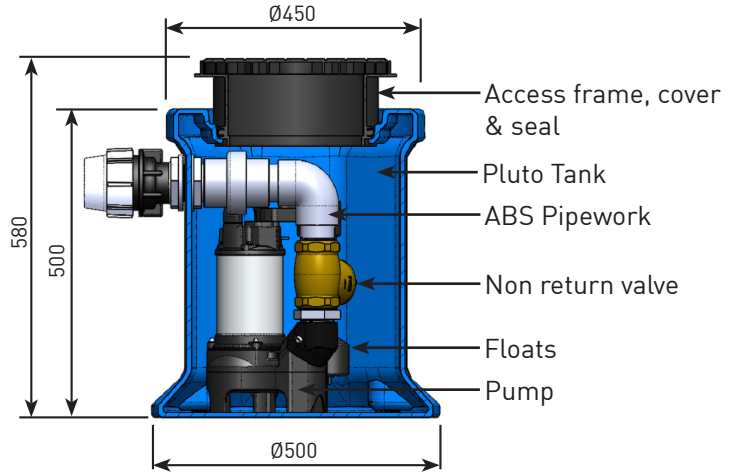

Please Note:

Due to varying environmental conditions during the manufacturing process, dimensions shown above have a tolerance of $\pm 2\%$.

Turret Assembly Exploded View

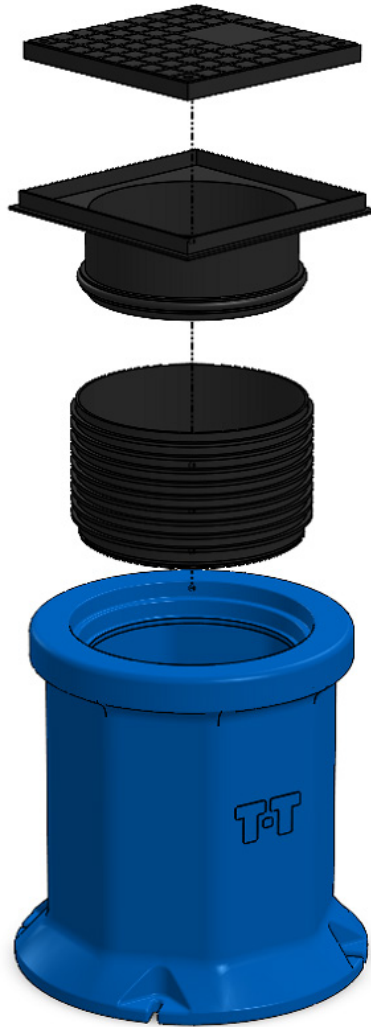

Notes

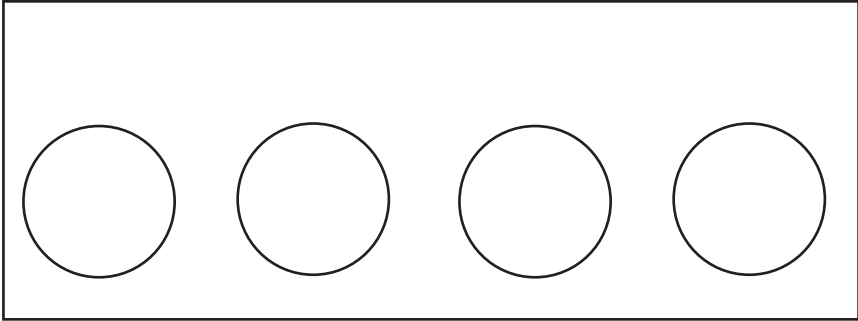

Cable Gland Entry Template
ø20mm Hole Saw Required



Notes



Notes

