

Pluto Package Pumping Station

Designed primarily for smaller foul and surface water applications, basement conversions, cavity wall drainage etc. the BBA Approved T-T Pluto range retains the same robust features of the Planet range, yet in a compact design.



The fully automatic system, available in either single, or dual configurations, is designed and built for reliability and long life, encompassing a high performance pump range that can be selected to meet your specific application.

All our pump stations are designed and manufactured in the UK.



Features

- Strong roto moulded Polyethylene chamber.
- Hexagonal shaped chamber body, with flat faces to accommodate our range of duct seals, and to allow for multiple inlet positions.
- 1x Ø110mm inlet seal to accommodate standard drainage connections.
- 1x Ø50mm seal for cable or ventilation duct.
- Pedestrian rated access frame and cover pre-fitted.
- 2" BSP discharge connection point.
- Available in single or dual pump configurations, 230v 1Ph or 400v 3Ph.
- **Version 1:** Single submersible pump with internal ABS pipework, non-return valve, and isolation gate valve. This system is operated by a mains powered control panel, (single phase only) featuring indicator light, audible alarm with mute button, via float switches.
- **Version 2:** Dual submersible pumps with internal ABS pipework, non-return valve and an isolation gate valve. This is operated by a mains powered dual control panel, (single phase only) featuring indicator light, audible alarm with mute button, via float switches.

*[For 400v 3Ph pump systems, see our Libra Maxi range of control panels]

Performance Curves

Drainage Water Pumps

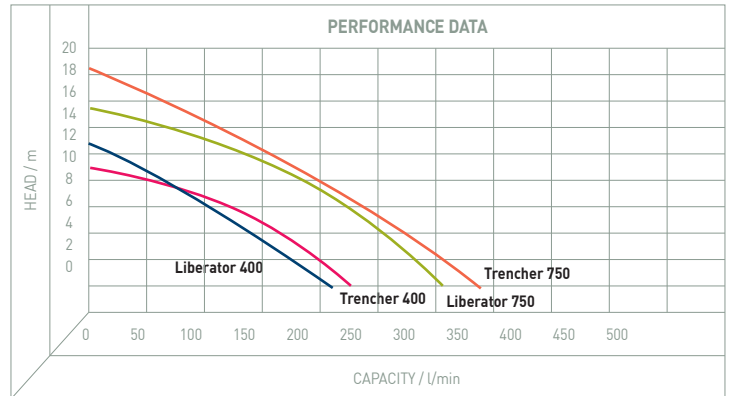
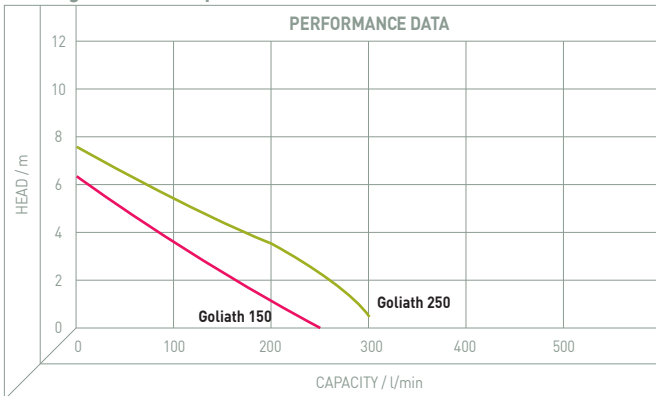

Sewage Water Pumps

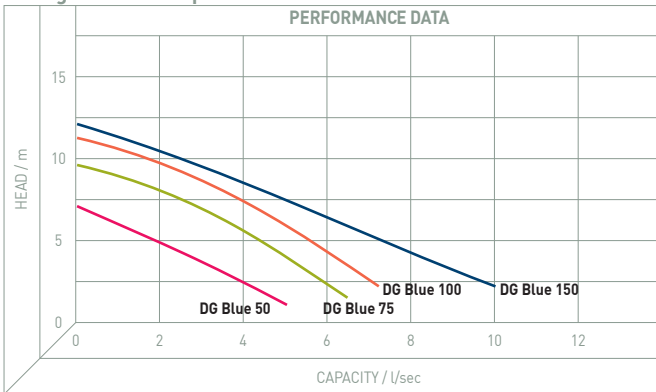

T-T DATA 1850 21/06/2023

Technical Data

PUMP TYPE.	CODE	MOTOR POWER		DISCHARGE		MAXIMUM		FREE PASSAGE mm	CABLE m	WEIGHT kg
		amp	kW	mm	inch	Head m	Capacity l/min			
GOLIATH SUPER 150 230V/1Ph	PM/GOLIATH1/1	1.6	0.15	50	2	6.3	250	30	5	8
GOLIATH SUPER 150 110V/1Ph	PM/GOLIATH1/2	2.8	0.15	50	2	6.3	250	30	5	8
GOLIATH SUPER 250 230V/1Ph	PM/GOLIATH2/1	2	0.25	50	2	7.5	300	30	5	8.5
GOLIATH SUPER 250 110V/1Ph	PM/GOLIATH2/2	4.2	0.25	50	2	7.5	300	30	5	8.5
LIBERATOR 400 110V/1Ph	PH/LIB400/110V	6	0.4	50	2	11	225	7	10	13
LIBERATOR 400 230V/1Ph	PH/LIB400/230V	3	0.4	50	2	11	225	7	10	13
LIBERATOR 400 400V/3Ph	PH/LIB400/400V	0.9	0.4	50	2	11	225	7	10	13
LIBERATOR 750 110V/1Ph	PH/LIB750/110V	11	0.75	50	2	15.8	300	7	10	16
LIBERATOR 750 230V/3Ph	PH/LIB750/230V	5.4	0.75	50	2	15.8	300	7	10	16
LIBERATOR 750 400V/3Ph	PH/LIB750/400V	1.9	0.75	50	2	15.8	300	7	10	16
TRENCHER 400 110V/1Ph	PH/T400/110V	6	0.4	50	2	12	220	7	10	13
TRENCHER 400 230V/1Ph	PH/T400/230V	3	0.4	50	2	12	220	7	10	13
TRENCHER 400 400V/3Ph	PH/T400/400V	0.9	0.4	50	2	12	220	7	10	13
TRENCHER 750 110V/1Ph	PH/T750/110V	11	0.75	50	2	18	350	7	10	15.5
TRENCHER 750 230V/3Ph	PH/T750/230V	5.4	0.75	50	2	18	350	7	10	15.5
TRENCHER 750 400V/3Ph	PH/T750/400V	1.9	0.75	50	2	18	350	7	10	15.5
DG Blue Pro 50/2/G40V 230V/1Ph	PZ/1082.005	2.8	0.37	40	1½	7	5.2	40	10	13
DG Blue Pro 50/2/G40V 400V/3Ph	PZ/1084.004	1.1	0.37	40	1½	7	5.2	40	10	13
DG Blue Pro 75/2/G40V 230V/1Ph	PZ/1086.005	4.1	0.55	40	1½	9.5	6.8	40	10	15
DG Blue Pro 75/2/G40V 400V/3Ph	PZ/1088.004	1.6	0.55	40	1½	9.5	6.8	40	10	15
DG Blue Pro 100/2/G40V 230V/1Ph	PZ/1078.005	5.6	0.74	40	1½	11	7.5	40	10	15.5
DG Blue Pro 100/2/G40V 400V/3Ph	PZ/1079.004	2.2	0.74	40	1½	11	7.5	40	10	15.5
*DG Blue Pro 150/2/G50V 230V/1Ph	PZ/1002.005	7.5	1.1	50	2	12	11	50	10	23
*DG Blue Pro 150/2/G50V 400V/3Ph	PZ/1003.002	3.2	1.1	50	2	12	11	50	10	23

*DG Blue Pro can only be supplied as a single pump system.
Other pump models are available, please speak with our Sales team.

Control Options

Our Libra Micro Controller is a simple, effective pump controller, available in both single and dual pump versions. They are suitable for 1Ph 230V 50Hz pump motors up to 9.3A full load current (FLC).

Comprising a host of user friendly features, such as power indication, fuse rupture detection, next pump in sequence indication (dual version only), audible alarm and volt free contacts for remote indication.

For 3Ph 400v Pluto pumping systems, please refer to our Libra Maxi range of control systems.



Dimensional & Part Details

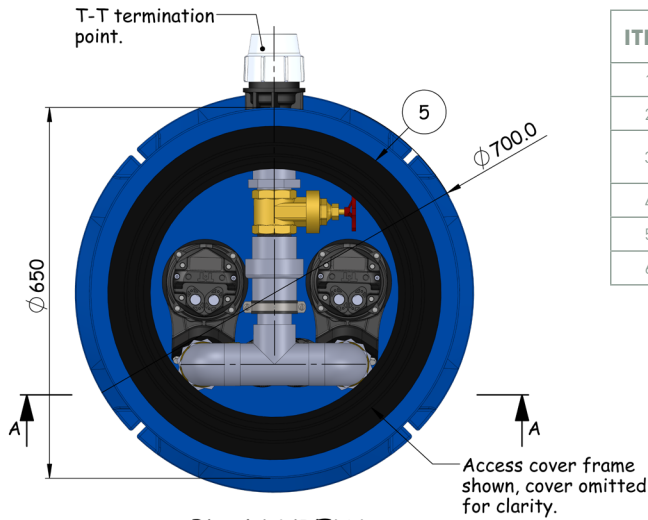

PLAN VIEW

ITEM	PART	MATERIAL
1	TANK	POLYETHYLENE
2	PIPEWORK & FITTINGS	ABS & BRASS
3	PUMP	STAINLESS STEEL / CAST IRON / ENGINEERED PLASTIC
4	FLOAT BRACKET KIT	STAINLESS STEEL
5	COVER & FRAME	POLYPROPYLENE
6	FLOAT	POLYPROPYLENE

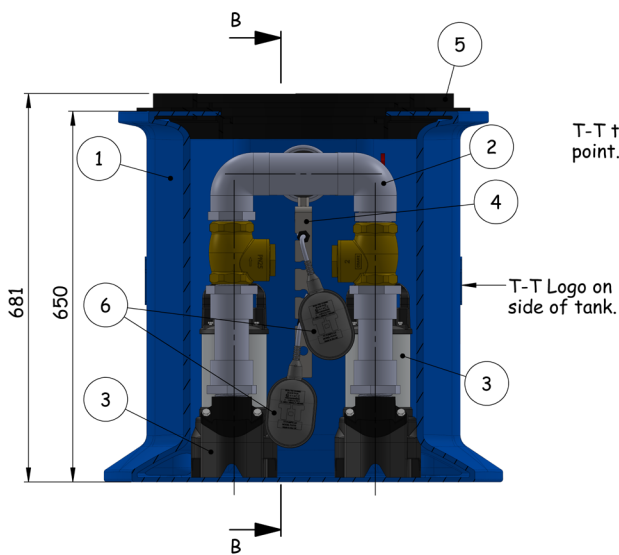

SECTION A-A

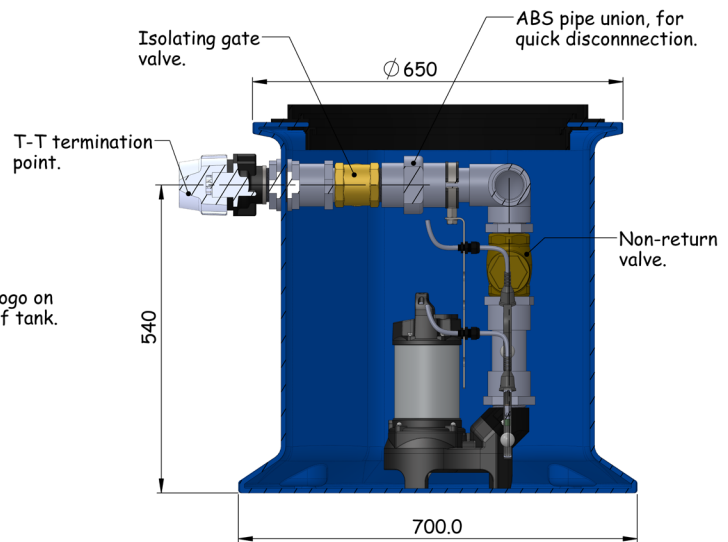

SECTION B-B

Also available:
T-T Pluto Extension turret kit, comprising neck, seal and neck clips.
This item CANNOT be retrofitted to previously installed tanks.

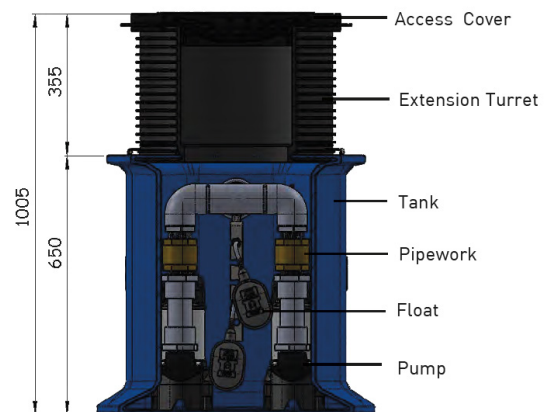

Please Note:
Due to varying environmental conditions during the manufacturing process, dimensions shown above have a tolerance of $\pm 2\%$

T-T DATA 1850 21/06/2023