

## T-T Utility Box

The T-T Utility Box (1, 2 & 3) is a high quality polypropylene tank intended for collecting water exclusively from domestic drains, including washing machines, showers and sinks.

Neatly constructed and with a small footprint, the Utility Box is very versatile and easy to install.



### Features

- Plug and play installation
- Polypropylene container with 10l usable volume
- Internal integral level control
- Audible alarm in case of critical high water level
- Free contact for an external alarm of washing machine stop button
- Pump is fixed to the container lid for ease of maintenance
- No cable gland on the container
- Separate connection for washing machine
- Fitted with one shower inlet (only 80mm off the floor)
- Operating temperature 40°C (short period: up to 90°C)
- Pressure outlet 1 1/4" with integrated check valve
- Ventilation by integrated active carbon filter
- 1.5 meter power cable
- Solids handling 10mm

### Performance Data

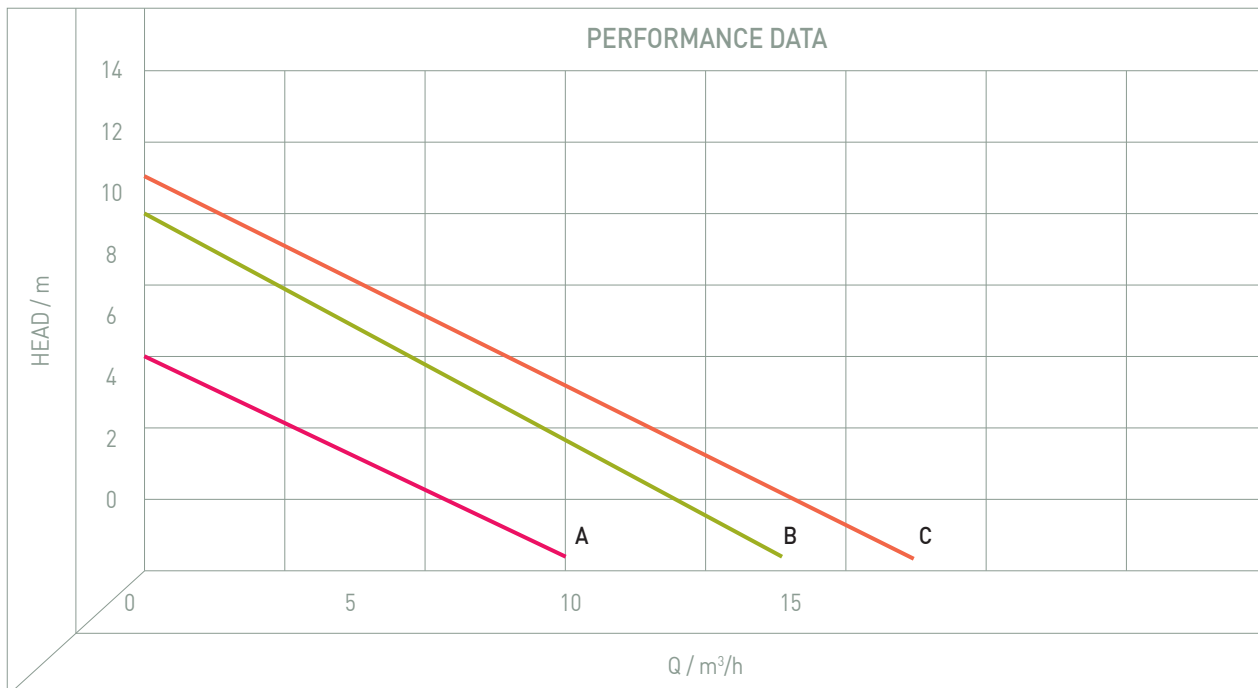

## Technical Specification

MODEL	CURVE	PUMP CODE	VOLTAGE	kW	Amp	RPM	Qmax (m³/h)	Hmax (m)	WEIGHT (kg)	
									PUMP	BOX
Utility Box 1	A \	PZN/UTILITYBOX-1	230	130	0.13	2800	8	6	10	5.0
Utility Box 2	B \	PZN/UTILITYBOX-2	230	430	0.43	2800	11.5	10	10	6.0
Utility Box 3	C \	PZN/UTILITYBOX-3	230	430	0.43	2800	14	11	10	7.0

## Parts List

ITEM NO.	QUANTITY	PART
1	1	Container
2+3	1	Cover with seal
4	1	Gasket
5	2	Closure SWH narrow side
5	2	Closure SWH long side
6	1	Pump for SWH 100
6	1	Pump for SWH 170
6	1	Pump for SWH 190
7	1	Shower intake compl.

ITEM NO.	QUANTITY	PART
14c	1	Lip sealing
14d	1	O-Ring 30x3
14e	1	Carbon Filter
14f	1	Gasket gray
14g	1	Terminal Cover
15	1	Reed sensor with floats
15	1	Circuit board with fuse

ITEM NO.	QUANTITY	PART
8	1	Pressure intake SWH
9	1	Non return valve gum
9	1	Threaded sleeve 5/4"
9	1	Screw 5/4"
10	2	Cable Gland
10a/b	1	Cable Gland
11	1	Nipple washing machine
12	1	Flat packing pressure
13	1	Power cable with plug
14a	1	Valve ball
14b	1	Valve core PE

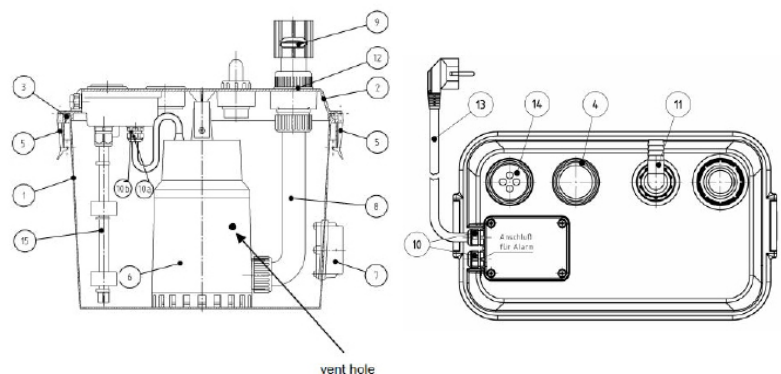

## Dimensional Drawings

