

Goliath 400 - Automatic Sump Pump

The Goliath Super® is a robust sump pump made of stainless steel plate and fibre-reinforced plastic, resistant to corrosion. It also features a vortex impeller giving up to 35mm solids handling. Maximum depth of submersion is 10m, minimum sump 250mm x 250mm.

Features:

- Stainless steel casing & reinforced plastic construction
- Double mechanical seal
- Interchangeable horizontal and vertical discharge
- Built in air relief valve on all models
- Automatic as standard but can be converted to manual upon request (except 400V)

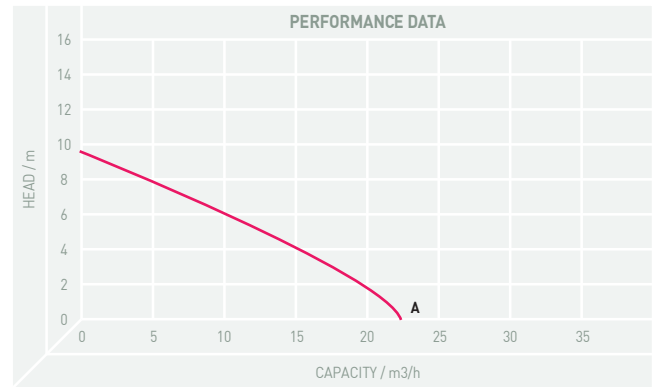

TECHNICAL SPECIFICATION

PUMP TYPE	PRODUCT CODE	CURVE	OUTPUT		DISCHARGE		MAXIMUM		FREE PASSAGE mm	CABLE	WEIGHT kg
			kW	AMP	mm	inch	HEAD M	CAPACITY LPM			
Goliath Super 400 230V	PM/GOLIATH3/1-A	A \	0.4	3.2	50	2	9.2	366	35	5	9.3
Goliath Super 400 400V	PM/GOLIATH3/2	A \	0.4	1.4	50	2	9.2	366	35	5	9.8

PARTS LIST AND DIMENSIONS

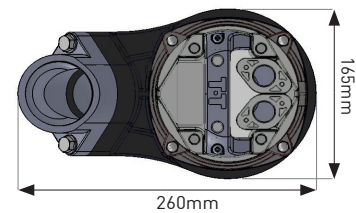
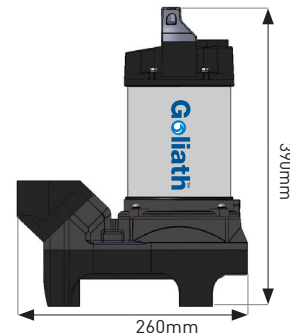
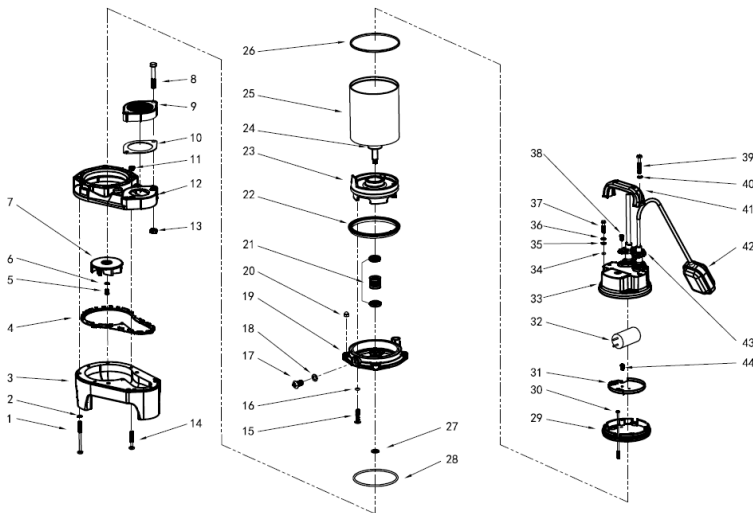

No.	PART	QTY	No.	PART	QTY	No.	PART	QTY	No.	PART	QTY
1	Screw	4	12	Casing	1	23	Lower Motor Cover	1	34	O Ring	4
2	Washer	4	13	Nut	2	24	Bearing	2	35	Washer	4
3	Casing Lower	1	14	Screw	2	25	Motor	1	36	Spring Washer	4
4	Casing Seal	1	15	Screw	4	26	Upper Motor Seal	1	37	Hex Bolt	4
5	Screw	1	16	O Ring	4	27	Oil Plug Seal	1	38	Screw	4
6	Washer	1	17	Screw	1	28	O Ring	1	39	Screw	2
7	Impeller	1	18	Seal Washer	1	29	Upper Motor Cover	1	40	O Ring	2
8	Screw	2	19	Oil Casing	1	30	Screw	1	41	Handle	1
9	Screwed Flange	1	20	Cap Nut	4	31	Capacitor Spacer	1	42	Float Switch	1
10	Flange Seal	1	21	Mechanical Seal	1	32	Capacitor	1	43	Cable Gland Cover	2
11	Nut	2	22	Lower Seal Ring	1	33	Capacitor Cover	1	44	Screw	1